

**ENCLOSED UPS INTERFACE MODULE**

**PSH2RB10**

Enclosed 4.00" Track Mount Power Control Center, 10 Amp Switch / Circuit Breaker, Two (2) 120 Vac Outlets, Terminals, 120 Vac Input. (No Status Contacts)

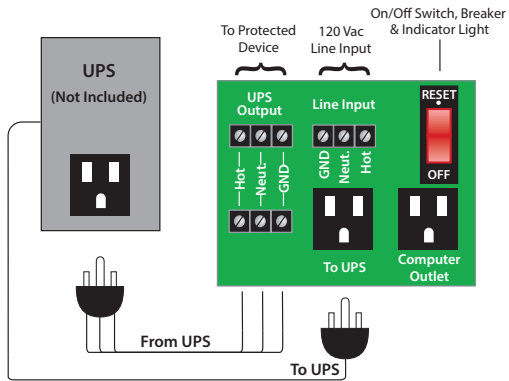

Shown Without Cover



Shown With Cover



**SPECIFICATIONS**

- Operating Temperature:** -30 to 140° F
- Humidity Range:** 5 to 95% (noncondensing)
- Main Breaker ON/OFF:** Switch / Breaker (10 Amp)
- Approvals:** UL Listed, UL916, C-UL
- Dimensions:** 12.000" x 14.000" x 6.000" Metal Housing with Screw Cover
- Weight:** 13.10 lbs.

- Notes:**
- Track mounted interface board may be ordered separately as model PSM2RB10, to be used with any commercial UPS with appropriate ratings for the circuit breaker.
  - Circuit breaker for short protection.
  - 14/3 Line Cord included (3').
  - Use with UPS devices rated 1000 VA or less.
    - Max. size: 12.000" x 7.250" x 5.500"
    - 120 Vac max., 600 W max., 8.3 Amp max.
  - UPS is not included.

POWER CONTROL