

S437A,B, S637A Sail Switches

PRODUCT DATA



FEATURES

- Micro Switch snap switch is operated by metal sail inserted in an air stream. (S437 switch is spst, S637 switch is spdt.)
- S637 has a set of normally closed contacts which can be used to energize a signal or warming circuit when the velocity drops off.
- Sail can be trimmed to one-half the original size to double the velocity required to close the snap switch contacts.
- Switch differential can be manually adjusted by turning a knurled knob on the snap switch.
- A conduit knockout is located on each end of the case for wiring convenience.

APPLICATION

The S437 and S637 Sail Switches respond to the air velocity in heating or warm air ducts, such as used in farm crop dryers. The switch completes a 24 V or line voltage burner control circuit only when the blower or fan has produced a predetermined air velocity.

SPECIFICATIONS

Mounting Position: Velocity characteristics listed apply when standard size sail is inserted in a horizontal air stream with the sail pivot in a vertical position. Vertical mounting with air movement upward is satisfactory; however, characteristics will change. Device cannot be vertically mounted with downward air movement.

Mounting Means: Case screw-mounts to duct wall with sail inserted through wall into air stream.

Mounting Dimensions: Refer to Fig 1.

Sail Size: Standard - 1 x 3 in. (25 x 76 mm).
Large - 1 1/2 x 4 in. (38 x 102 mm).

Contents

Application	1
Features	1
Specifications	1
Ordering Information	2
Installation	3
Wiring	3
Checkout	3



MODEL NO.	INCLUDES CASE AND COVER	SWITCHING ACTION ON INCREASING VELOCITY	SWITCHING ACTION ON DECREASING VELOCITY	SWITCH DIFFERENTIAL
S437A	YES	Spst. Normally open contacts close at 1900-2250 fpm (9.7 - 11.4 m/s). Varies directly with differential setting.	Switch de-energizes at 1350 fpm (6.9 m/s). Not adjustable.	Adjustable, 550-900 fpm (2.8 - 4.6 m/s)
S437B	NO			
S637A	YES	Spst. One set of contacts opens, one set closes at 1900-2250 fpm (9.7 - 11.4 m/s). Varies directly with differential setting	One set of contacts opens to de-energize blower, one set closes to energize warming circuit at 1350 fpm (6.9 m/s). Not adjustable.	

Maximum Ambient Temperature: 150° F (66° C).

Insertion Length: Standard - 3 1/2 in. (89 mm).
Large - 4 1/2 in. (114 mm).

Switch Contact Rating (amperes):

	120 Vac	240 Vac
Full Load	8	5.1
Locked Rotor	48	30.6

2 A at 24 Vac.
15 A at 6 Vac.
7.5 A at 12 Vdc.

Cover Finish: Red enamel.

Underwriters Laboratories Inc. Listed:

S437A, S637A - File No. MP2169, Vol. 2 dated 5-11-59; Guide No. MFHX.
S437B - File No. MP2168, Vol. 2 dated 5-11-59; Guide No. MFHX2 (Component Recognized).

Canadian Standards Association Certification: Listed S, File No. LR95329, Class 481302.

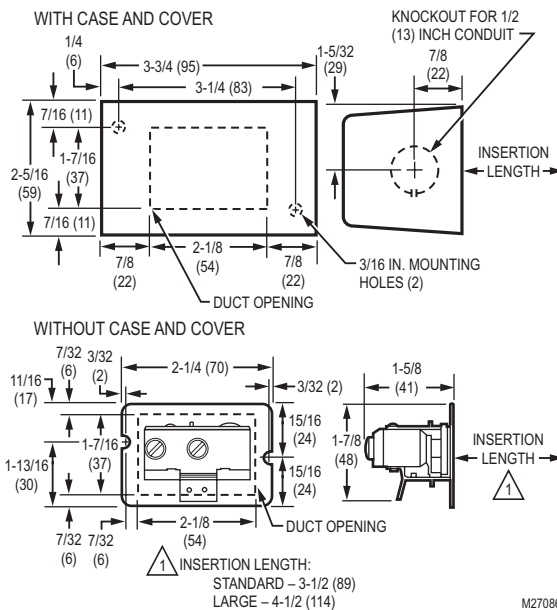

Fig. 1. S437 Dimensions in in. [mm in Brackets].

ORDERING INFORMATION

When purchasing replacement and modernization products from your TRADELINE® wholesaler or distributor, refer to the TRADELINE® Catalog or price sheets for complete ordering number.

If you have additional questions, need further information, or would like to comment on our products or services, please write or phone:

1. Your local Honeywell Automation and Control Products Sales Office (check white pages of your phone directory).
2. Honeywell Customer Care
1885 Douglas Drive North
Minneapolis, Minnesota 55422-4386

In Canada—Honeywell Limited/Honeywell Limitée, 35 Dynamic Drive, Toronto, Ontario M1V 4Z9.

International Sales and Service Offices in all principal cities of the world. Manufacturing in Australia, Canada, Finland, France, Germany, Japan, Mexico, Netherlands, Spain, Taiwan, United Kingdom, U.S.A.

INSTALLATION

When Installing this Product...

1. Read these instructions carefully. Failure to follow them could damage the product or cause a hazardous condition.
2. Check the ratings given in the instructions and on the product to make sure the product is suitable for your application.
3. Installer must be a trained, experienced service technician.
4. After installation is complete, check out product operation as provided in these instructions.



CAUTION

Disconnect power supply before connecting wiring to prevent electrical shock and equipment damage.

Mounting

Plan the location so that the sail will be in the direct path of an unrestricted air stream. A horizontal duct run is best because the sail will then move horizontally. In a vertical duct, the effect of gravity on the linkage changes the operating characteristics somewhat.

1. At the desired location, cut a rectangle hole 1-1/2 x 2 in. See dotted lines in dimension drawing.
2. Note direction of air stream and position chassis as a template to make the two mounting hole locations.
3. Center punch and drill mounting holes. Secure device with sheet metal screws.

WIRING

Disconnect power supply before making wiring connections to avoid possible electrical shock or equipment damage. All wiring must agree with local codes and ordinances.

Wire the sail switch in series with the load to act as an air velocity limit switch.

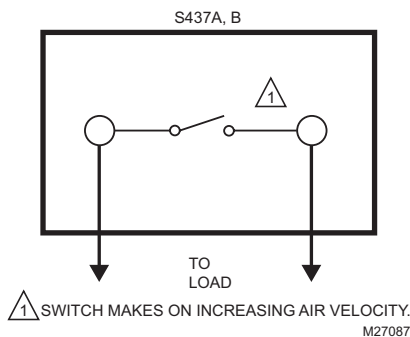

Fig. 2. S437 Schematic and Typical Connections

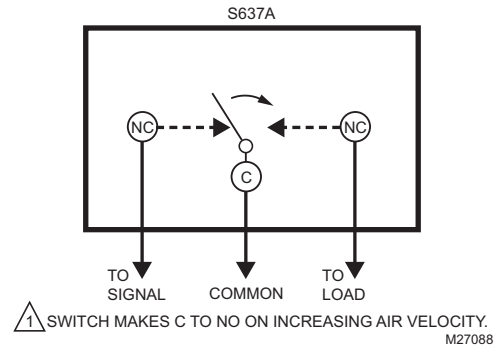

Fig. 3. S637 Schematic and Typical Connections.

Set Differential

The knurled wheel at the base of the switch is marked with the letters A, B, C, D to indicate relative differentials from minimum to maximum. Follow instructions of system manufacturer, if available, or adjust to suit actual operation.

A minimum differential setting (position A) of approximately 550 fpm (2.8 m/s) results in a make velocity of approximately 1900 fpm (9.7 m/s). The break velocity is 1350 fpm (6.9 m/s) for any setting of the differential.

Sail Size

All velocities given above are for a standard size sail. The large sail operates the switch at reduced velocities.

To control at higher velocities, the size of the sail must be reduced in inverse proportion.

Example: 2 x velocity = 1/2 sail size.

CHECKOUT

Operate the system through at least one complete cycle to make certain all equipment is controlled properly.

By using this Honeywell literature, you agree that Honeywell will have no liability for any damages arising out of your use or modification to, the literature. You will defend and indemnify Honeywell, its affiliates and subsidiaries, from and against any liability, cost, or damages, including attorneys' fees, arising out of, or resulting from, any modification to the literature by you.

Automation and Control Solutions

Honeywell International Inc.
1985 Douglas Drive North
Golden Valley, MN 55422
customer.honeywell.com

Honeywell Limited-Honeywell Limitée
35 Dynamic Drive
Toronto, Ontario M1V 4Z9

