

# ML6984 Direct Coupled Valve Actuator

## PRODUCT DATA



## FEATURES

- Allows the use of one common transformer power supply for multiple actuators and controllers
- Self-contained, motorized valve linkage
- Linkage self-adjusts to valve stroke of up to 19mm (3/4")
- Multipose mounting
- Strong valve seat closing force 710 Newton (160 lbs.)
- Compact size for easy installation in confined area
- One device for either Vac or Vdc power supply application
- Electronic current sensing provides internal protection and positive full closing force
- Field-addable auxiliary switches available
- Compatible with 3-wire or 5-wire control systems

## APPLICATION

The ML6984 is a self-contained, self-adjusting, linear motorized linkage that mounts directly onto V5011 two-way or V5013 three-way valves and provides up to 19 mm (3/4") of linear travel (stem lift). For use with low voltage 3-wire SPDT Series 20 (on-off), Series 60 (floating) electro-mechanical (dry contacts) or electronic (triac) output controllers.

## Contents

Specifications.....	2
Order information.....	2
Installation.....	3
Wiring Schematics.....	5
Operation and Checkout.....	6



## SPECIFICATIONS

### **IMPORTANT:**

*The specifications given in this publication do not include normal manufacturing tolerances. Therefore, an individual unit may not exactly match the listed specifications. Also, this product is tested and calibrated under closely controlled conditions and some minor differences in performance can be expected if those conditions are changed.*

### **Ambient Rating:**

Operating Temperature:

0°C to 55°C (32°F to 131°F)

Shipping Temperature:

-40°C to +65°C (-40°F to 150°F)

Relative Humidity:

15% to 95% at 40°C (104°F)

### **Acoustic Noise:**

55 dBA max. Sound Pressure Level at 1 m (39") distance.

### **Electrical Ratings:**

Power supply/consumption:

24V (Nominal), 50/60Hz or

24 to 28 Vdc

6VA(Running), 12VA(Valve seating)

### **Shipping Weight:**

Approx. 1 kg (2.2 lbs)

### **Accessories/Parts:**

272630A--Auxiliary switch assembly (1-SPDT)

272630B--Auxiliary switch assembly (2-SPDT)

272775-- Replacement motor brush kit

40003793-005--Mounting hardware bag assembly

### **Mechanical Ratings:**

Stroke--19mm (3/4") or less

Stroke timing-- Approx. 63 seconds for 3/4" stroke

Closing Force-- 710N (160 lbs.) Nominal\*

\*Rating applies to both directions.

### **Performance Specifications:**

Minimum Signal Input Duration: 200 milli-second

Life Expectancy-- (at rated load and power conditions) 50,000 full stroke cycles plus 1,000,000 repositions at 10% stem travel or 10 years, whichever occurs first.



## **CAUTION**

**Minimum required control signal input duration is 200 milli-second. Short and rapid cycling/repositioning will result in possible device lock-up or reduced service life.**

## ORDERING INFORMATION

When purchasing replacement and modernization products from your wholesaler or distributor, refer to the price sheets for complete ordering number, or specify--

1. Model number.
2. Valve body type and model number.
3. Accessories, if desired.

If you have additional questions, need further information, or would like to comment on our products or services, please write or phone:

1. Your local Honeywell Home and Building Control Sales office (Check white pages of your phone directory).
2. Home and Building Control Customer Service Department  
Honeywell Limited/Limitee  
155 Gordon Baker Road  
North York, Ontario  
Canada M2H 3N7

In U.S.A. -- Honeywell Inc. 1985 Douglas Drive North, Minneapolis, Minnesota 55422-4386 (612) 951-1000

International Sales Offices in all principal cities of the world. Manufacturing in Australia, Canada, Finland, France, Germany, Japan, Mexico, Netherlands, Spain, United Kingdom, U.S.A.

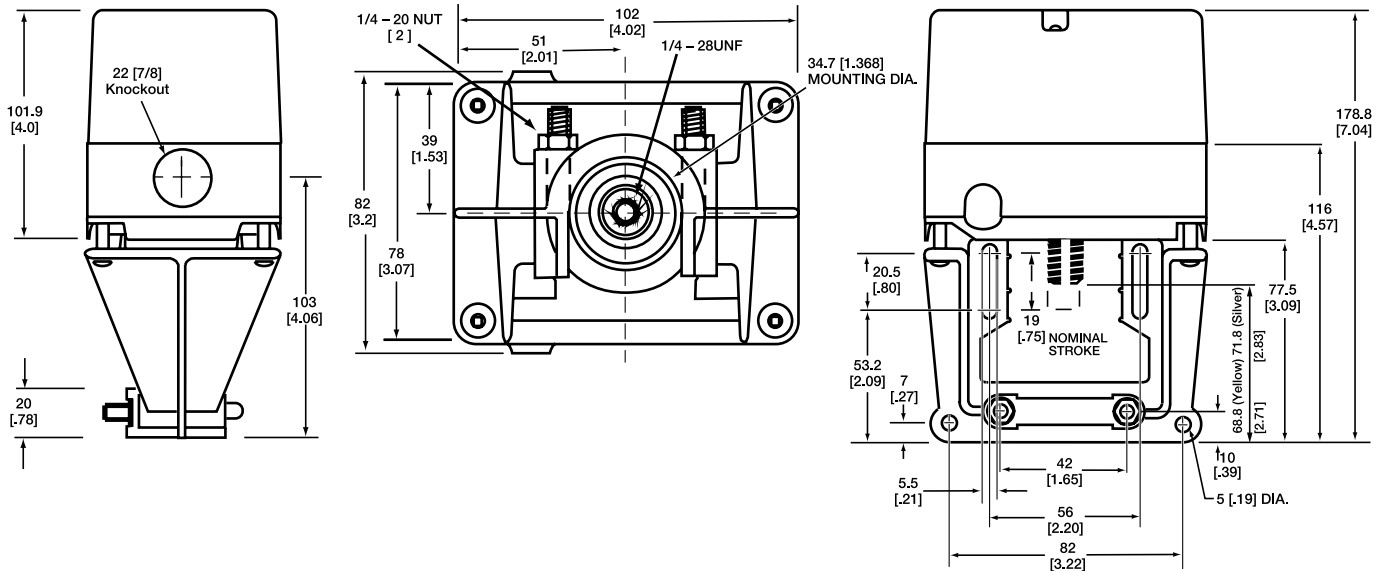

FIG. 1 -- DIMENSIONS OF ML6984 VALVE ACTUATOR IN MM (INCHES).

## INSTALLATION

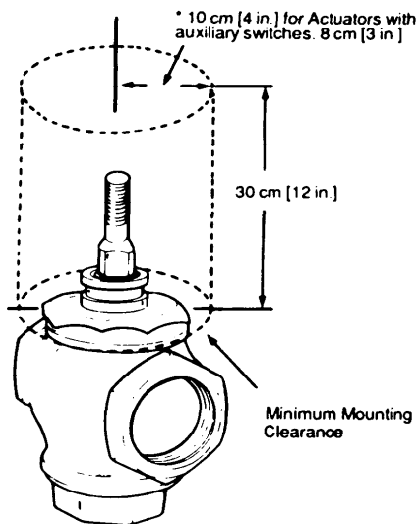

FIG.2 -- MINIMUM MOUNTING CLEARANCE.

## ! CAUTION

1. Installer must be a trained service technician.
2. **DO NOT electrically operate the ML6984 before assembly to the valve because damage not apparent to the installer may occur.**

### Mounting:

1. Ensure that the valve body is installed correctly, that is, the arrow points in the direction of the flow.
2. Although the actuator can be mounted in any position, it is preferable that the ML6984 is mounted above the valve body. This will minimize the risk of damage to the ML6984 in the event of condensation or a valve gland leak.
3. Remove the stem button (Fig. 3) from the valve stem. Save the set screw inside the stem button for later installation. The button itself is not needed.
4. Slide the position indicator (plastic disk or rubber O-ring) over the valve stem. (See inset, Fig. 3) Indicator will self-align to the marking on the yoke after one complete operating cycle.

### Assembly of ML6984 to the valve:

1. The drive shaft of the ML6984 has a threaded hole to link with the valve stem. Slide the yoke over the valve bonnet (Fig. 4)
2. Thread the ML6984 drive shaft onto the valve stem **all the way**, until it is **completely attached (with no threads showing)**, by turning the valve actuator in a clockwise direction, as viewed from above (depending on the valve models, use a pin or wrench to keep valve stem from turning). Note that the valve actuator is shipped with drive shaft in the mid-position.
3. Care should be exercised when using tools on the valve stem during tightening. (Fig.4) **DO NOT** damage the threads or other parts of the stem.
4. Orient the conduit hole to the most desirable direction, then tighten the LOCKNUTS on the U-bolt.

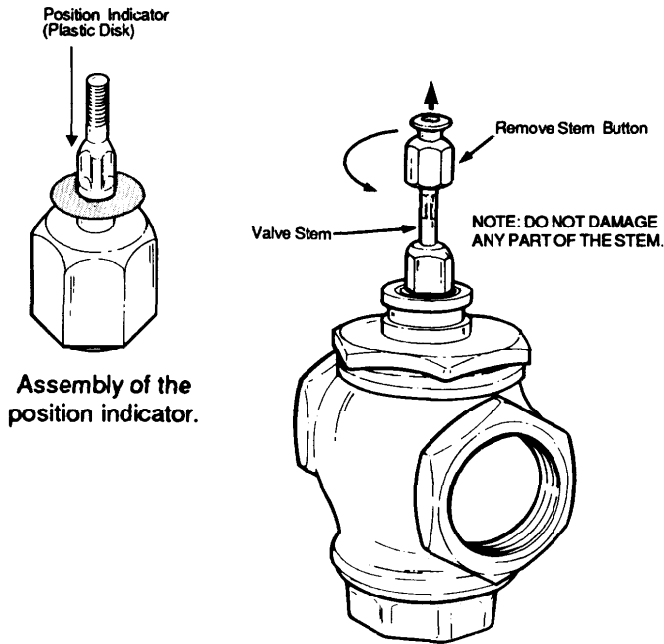

FIG.3 -- PREPARATION FOR VALVE ASSEMBLY.

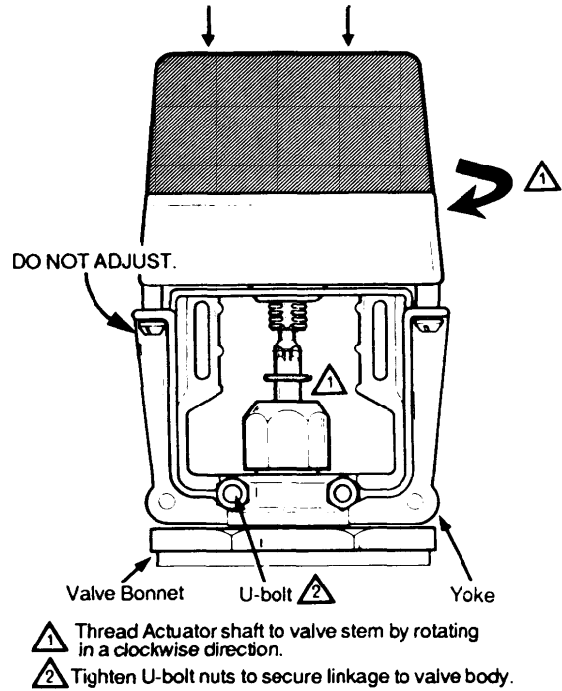

FIG. 4 -- ASSEMBLY OF ML6984A TO VALVE.

5. Remove the plastic cover from the ML6984 by loosening the two screws located on the top (Note: These screws are captive. Rotate three complete revolutions to remove cover ). Drop either Slot Headed or Allen Hex type of set screw (both are included in the plastic bag ) into the top of the shaft, slotted/ Hexed side up. Or use the set screw from the valve stem button.
6. Depending on which type of set screw was used, with a 5 mm (3/16") Slotted screwdriver or 1/8"x 6" Allen wrench (included in the plastic bag), **tighten the set screw to lock valve stem in place** (Fig. 6).

**! CAUTION**

For proper valve operation, valve stem must be **threaded into the actuator all the way (with no threads showing) and locked in place** with the set screw provided.

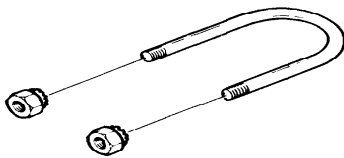

FIG. 5 -- U-BOLT ASSEMBLY.

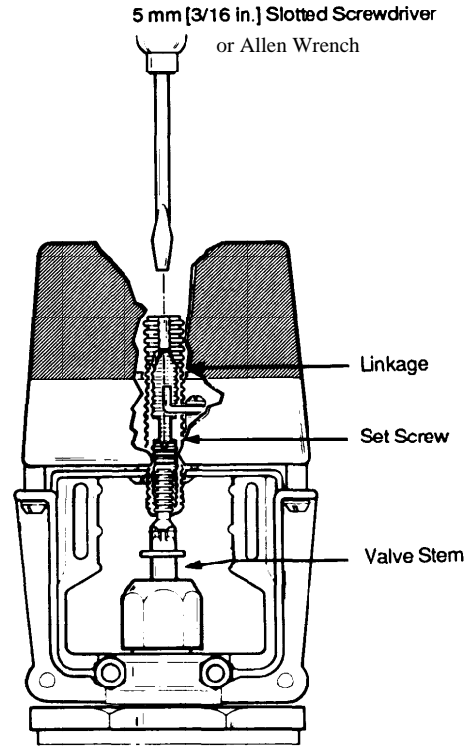

FIG. 6. -- LOCKING ML6984A DRIVE SHAFT TO VALVE STEM

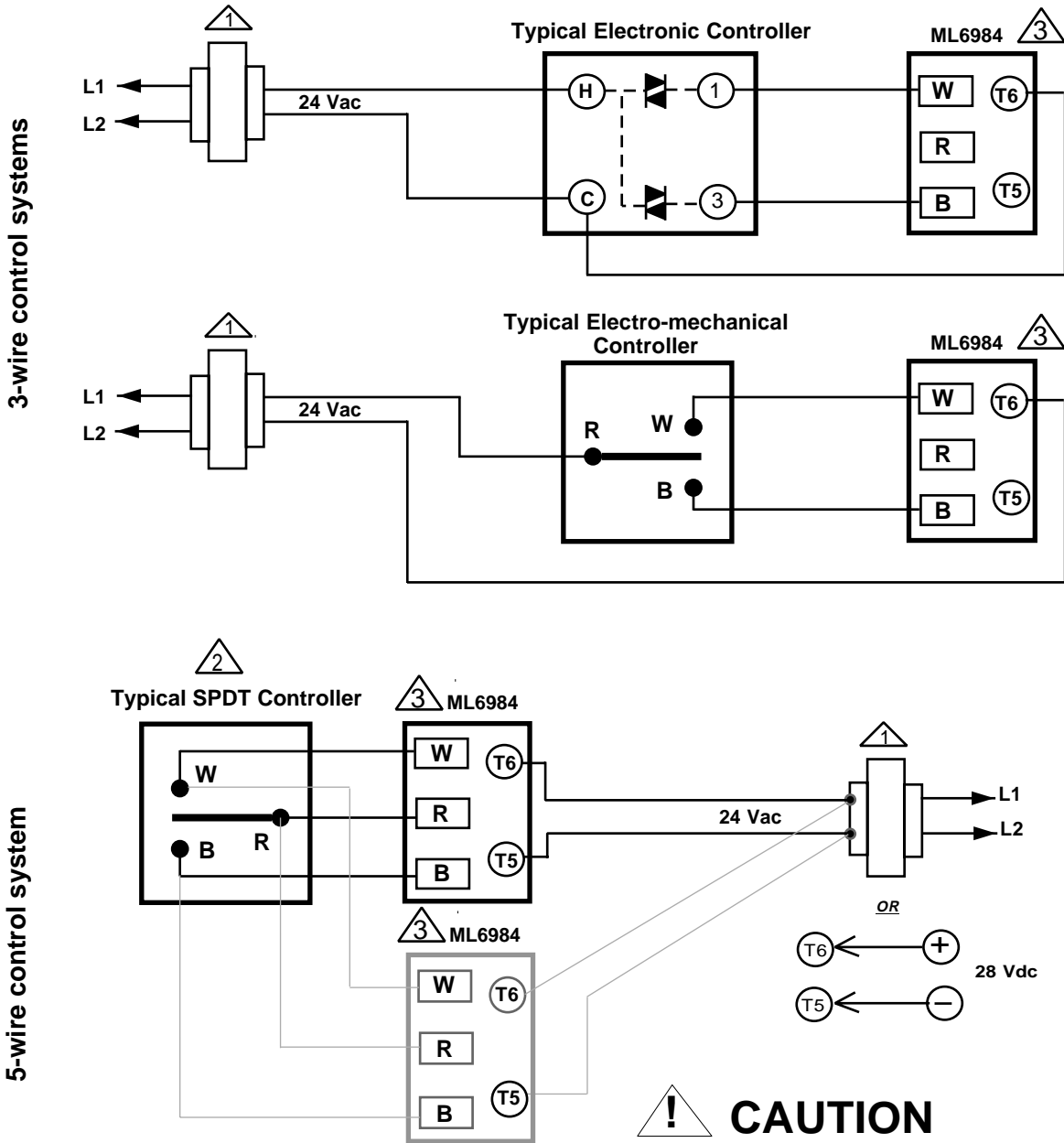

Fig. 7 Wiring for ML6984 actuators

**Operation:**

The recommended valve actuator power source is a class 2, 24V transformer or 28Vdc across terminals T5 & T6. Internal circuitry provides dc power for the electronic sensing and drive motor circuits.

The motor is controlled by a microprocessor. Connecting B to R tells the microprocessor to cause the actuator to drive open. Connecting W & R will cause the actuator to drive closed. For "floating" control, if R remains open, the actuator will remain in the last position.

At the end of the valve stroke, the actuator will develop the necessary force for positive valve close-off. As forces are developed, the current to the motor increases. The microprocessor stops the actuator automatically when the motor current, and forces reach the predetermined level.

 **CAUTION:**

1. Disconnect power supply before beginning installation to prevent electrical shock and equipment damage.
2. All wiring must comply with applicable local electrical codes, ordinances and regulations.
3. Make certain that the voltage and frequency of the power supply correspond to the rating of the device.
4. **DO NOT electrically operate the ML6984 before assembly to the valve because damage not apparent to the installer may occur.**

**GENERAL NOTE:**

For proper operation, voltage on the T5 & T6 **must not be less than 22Vac** or 24Vdc during running or force generating stages.

**REPLACEMENT NOTE:**

**To replace ML684:**

1. The new ML6984 is a direct replacement for the old ML684A in single actuator or parallel multiple actuators hook-up. The old and new actuators can be mixed in the same electrical circuit. For multiple actuators controlled by a common controller in parallel, these actuators must be wired so that they all travel in the same direction.
2. When replacing the ML684A1009 (80 lbs ) with this new ML6984 on the V5045 valve. The already installed valve adaptor (part # 272629A) on the valve stem and actuator assembly is still needed.

**To replace ML6874:**

1. The new ML6984 is a direct replacement for the old ML6874 in single actuator hook-up.
2. For parallel multiple old ML6874 actuators applications, an isolation relay must be used (isolation relay contacts should be placed in the new ML6984 actuator signal input "W" and "B" circuit).

**Checkout:**

1. Make sure the valve stem is completely screwed into the actuator drive shaft with no threads showing.
2. Make sure the valve stem is locked in place with the set screw.
3. With 24 Vac or 28Vdc power supply connected to T5 & T6.
4. Jumper R & B. The valve stem should move up.
5. Jumper R & W. The valve stem should move down.
6. For Floating operation, open R connection. Valve stem should remain in position.
7. Re-connect all control wiring.
8. Operate the system (valve, actuator and controller) for several cycles to ensure proper installation.
9. When checkout is complete, return the controller to the desired setting.

**Home and Building Control**  
Honeywell Limited/Limitee  
155 Gordon Baker Road  
North York , ON  
Canada M2H 3N7

**Home and Building Control**  
Honeywell Inc.  
1985 Douglas Drive North  
Golden Valley, MN 55422

By using this Honeywell literature, you agree that Honeywell will have no liability for any damages arising out of your use or modification to, the literature. You will defend and indemnify Honeywell, its affiliates and subsidiaries, from and against any liability, cost, or damages, including attorneys' fees, arising out of, or resulting from, any modification to the literature by you.

**Honeywell**