

VC2, VC4, VC60, VC8

On-Off Actuator for VC Series Balanced Hydronic Valves



These 2-position (open/close) control **actuators** are used with VCZ 1000, 1100, 6000 and 6100 series hydronic valves in a normal indoor environment to provide quick opening/closing to control the flow of hot and/or chilled water or glycol solution to 60% concentration. They are designed for on-off "zone" control of heating/cooling systems, or to control individual fan coil, baseboard radiator or convector applications.

Depending on the model selected, the actuator can be controlled by a low or line voltage SPST or SPDT controller, such as a room thermostat, aquastat or flow switch.

VC80 series valve actuators are designed to be used with hard-wired electronic thermostats with series anticipator or power-stealing thermostats. Recommended control thermostats include T8601D, T8401C, T8380 and T8360 families.

VC actuators use cam-operated cartridge travel to resist water hammer. Internal limit switches prevent motor overrun.

SPECIFICATIONS

The specifications following are nominal and conform to generally accepted industry standards. Honeywell is not responsible for damages resulting from misapplication or misuse of its products.

Voltage:

24V 50Hz ; 24V 60Hz Models
100-130 V 50-60 Hz Model
200-240 V 50-60 Hz Model

Label Colour Code

Blue
Black
Red

Power consumption:

6 Watts Max. at nominal Voltage (during valve position change).
Use 24 V Class 2 transformer.

Provide 6 VA per valve for transformer and connection wire sizing.

Maximum Duty Cycle: 15%

Nominal timing:

Valve opens in 6 seconds @ 60 Hz (20% longer @ 50 Hz).

VC8040 Series opens in 12 seconds @ 60 Hz (20% longer @ 50 Hz).

Electrical termination:

Available in 3 versions:

(1) Molex™ (header # 39-30-1060). Requires mating

connector (receptacle/housing # 39-01-2060). OR

(2) integral 1 meter [nominal 39"] leadwire cable.

(3) 5 feet [1.5 meter] plenum-rated cable per UL94-5V.

Includes plastic adapter for use with 3/8" flexible conduit.

End switch rating :

2.2 A inductive from 5 to 110 Vac,

1.0 A inductive above 110 to 277 Vac.

Min. DC switching capability: 5 mA @ 24 Vdc

Operating ambient temperature:

0 to 65°C [32 to 150°F]

Except VC2114, VC2714, VC8114 & VC8714 are 0 to 60°C [32 to 140°F]

Humidity Rating:

5-95% RH (non-condensing)

Fluid temperatures:

34 to 203°F [1 to 95°C]

Shipping & storage temperature:

-40 to +65°C [-40 to +150°F]

Atmosphere:

non-corrosive, non-explosive

Nominal Dimensions (Actuator only):

3-23/32" width x 2-11/16" depth x 2-3/4" height

94 mm width x 68 mm depth x 70 mm height

Accessories:

272866B Valve Flushing Cap

MODELS:

Actuator Only: VC2, VC4, VC60, VC8 (See Table 1)

Bodies (Order Separately): VCZ..., (See 95C-10919)

Actuators				
Model No.	Power	Control Input	Auxiliary Switch	Special Features
INTERNATIONAL MODEL [3]				
VC2010zz00	24V~50Hz	SPDT	--	Molex
VC2011zz00	24V~50Hz	SPDT	--	Cable
VC2012zz00 [1]	24V~50Hz	SPDT	--	Molex
VC2611zz00	24V~50Hz	SPDT	Yes	Cable
VC4012zz00	200-240V~50-60Hz	SPST	--	Molex
VC4013zz00	200-240V~50-60Hz	SPST	--	Cable
VC4013zz11	200-240V~50-60Hz	SPST	--	Cable
VC4613zz00	200-240V~50-60Hz	SPST	Yes	Cable
VC6012zz00	200-240V~50-60Hz	SPDT	--	Molex
VC6013zz00	200-240V~50-60Hz	SPDT	--	Cable
VC6013zz11	200-240V~50-60Hz	SPDT	--	Cable
VC6612zz00	200-240V~50-60Hz	SPDT	Yes	Molex
VC6613zz00	200-240V~50-60Hz	SPDT	Yes	Cable
VC8011zz00	24V~50Hz	SPST	--	Cable
VC8611zz00	24V~50Hz	SPST	Yes	Cable
NORTH AMERICA MODELS [3]				
VC2114zz11	24V~60Hz	SPDT	--	Plenum[2]
VC2714zz11	24V~60Hz	SPDT	Yes	Plenum[2]
VC4011zz11	120V~60Hz	SPST	--	Cable
VC4013zz11	200-240V~50-60Hz	SPST	--	Cable
VC8111zz11	24V~60Hz	SPST	--	Cable
VC8114zz11	24V~60Hz	SPST	--	Plenum[2]
VC8711zz11	24V~60Hz	SPST	Yes	Cable
VC8714zz11	24V~60Hz	SPST	Yes	Plenum[2]

Note:

[1] with Snubber circuit

[2] Plenum rated with 5 meter cable

[3] Some models are not available in all countries. Not all VC Actuator modes are shown.

Table 1 - Actuator Model Identifiers

VC Valve Assembled dimensions for reference (Figure 1 & Table 2):

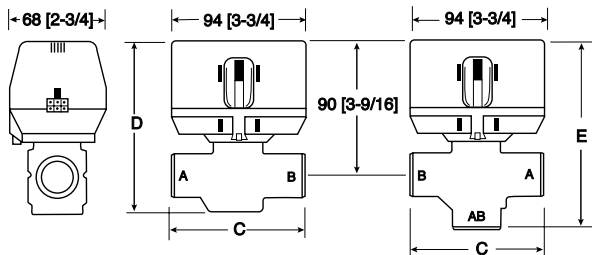

Figure 1 - Nominal dimensions in inches and millimetres

[4] Pipe Fitting Sizes	Dimension		C		D		E	
	mm	Inches	mm	Inches	mm	Inches	mm	Inches
1/2" BSPP (int.) [2]	98	3-7/8	111	4-3/8	136	5-11/32		
1/2" BSPT (int.)								
3/4" BSPP (int.)								
3/4" BSPT (int.)	94	3-11/16			113	4-7/16	130	5-1/8
3/4" BSPP (ext.)								
22mm Compression [3]	112	4-7/16					140	5-1/2
1" BSPP (int.)	94	3-11/16					136	5-11/32
1" BSPP (ext.)	95	3-11/17	114	4-7/17			137	5-11/33
1" BSPT (int.)	94	3-11/16			113	4-7/16	136	5-11/32
28mm Compression [3]	116	4-9/16					147	5-13/16
NORTH AMERICA STANDARD MODELS								
3/8" FLARE [1]	98	3-7/8					136	5-11/32
1/2" SWEAT	89	3-1/2			111	4-3/8	130	5-1/8
1/2" FLARE [1]								
1/2" INVERTED FLARE [1]	98	3-7/8					136	5-11/32
1/2" NPT (int.)								
3/4" NPT (int.)							130	5-1/8
3/4" SWEAT	94	3-11/16	113	4-7/16			132	5-3/16
1" NPT (int.)							136	
1" SWEAT								5-11/32
1-1/4" SWEAT								
1-1/4" NPT (int.)	110	4-5/16	118	4-5/8	142	5-5/8		

[1] No adapters

[2] Suitable for use as 15 mm compression fitting

[3] Dimensions shown with nuts and olives installed

[4] **Some models not available in all countries**

Table 2 - VC Valve assembled dimensions

MANUAL OPENER

The manual opener can be manipulated only when in the up position. The motorized valve can be opened by firmly pushing the red manual lever down to midway and in. This holds the valve in the open position. This "manual open" position may be used for filling, venting, draining the system or for opening the valve in case of power failure. The valve can be restored manually to the closed position by depressing the red manual lever lightly and then pulling the lever out. The valve and actuator will return to the automatic position when power is restored.

NOTE: If the valve is powered open (the lever is down), it can not be manually closed unless actuator is removed.

INSTALLATION

WHEN INSTALLING THIS PRODUCT:

1. Read these instructions carefully. Failure to follow them could damage the product or cause a hazardous condition.
2. Check the ratings given in the instructions and on the product to make sure the product is suitable for your application.
3. Installer must be a trained, experienced service technician.
4. Always conduct a thorough checkout when installation is completed.
5. While not necessary to remove the actuator from the body, it can be removed for ease of installation. The actuator can be installed in any position to suit the most convenient wiring mode.
6. An extra 1" (25 mm) head clearance is required to remove the actuator.



CAUTION:

Disconnect power supply before connecting wiring to prevent electrical shock and equipment damage.

On 24 V systems, **never** jumper the valve coil terminals, even temporarily. This may damage the thermostat.

PLUMBING

Refer to the VC Series Cartridge Valve Installation and Instruction sheet, form number 95C-10919, for plumbing instructions.



IMPORTANT:

For trouble-free operation of the product, good installation practice must include initial system flushing, chemical water treatment, and the use of a 50 micron (preferably 5 micron) 10% side stream system filter(s). Remove all filter(s) before flushing. Limit flow through the filter to 5~10% of total system flow to prevent 'starving' the system. Ensure filter cartridge is changed frequently enough to prevent clogging.

Put the VC actuator manual lever in the manual open or the fully open (down) position to allow initial system flushing with the actuator mounted. This may be done without electrical hook-up. Alternatively, reusable flush caps, part # 272866B, may be purchased separately for use in initial flushing of dirty hydronic systems.

Do not use boiler additives, solder flux and wetted materials which are petroleum based or contain mineral oil, hydrocarbons, or ethylene glycol acetate. Compounds which can be used, with minimum 50% water dilution, are diethylene glycol, ethylene glycol, and propylene glycol (antifreeze solutions).

TO INSTALL ACTUATOR

Installation of the actuator does not require draining the system, provided the valve body and valve cartridge assembly remain in the pipeline. Wiring may be done either before or after the actuator is installed.

1. The actuator head is automatically latched to the valve. Align the coupling hole in the bottom of the actuator with the valve stem. Press the actuator down towards the body with moderate hand force and turn the actuator counter-clockwise by 1/8 turn (45 degrees) to line up the actuator with the piping. The latch will click when engaged. See Figure 2.
- NOTE:** The actuator can also be installed at right angles to the valve body but in this position the latch mechanism will not engage.
2. Connect leadwires. See Figure 3 for flexible conduit installation with plenum-cable models.

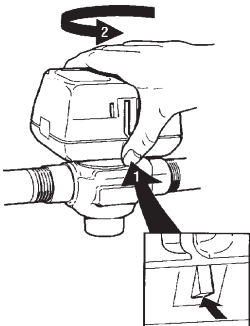

Figure 2 - Latch Mechanism to detach Actuator

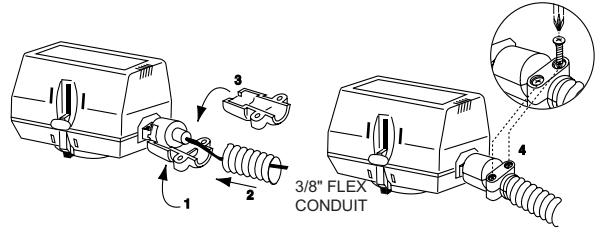

Figure 3 - Flexible Conduit Attachment

WIRING

NOTE: Each 3-wire (SPDT) actuator must have individual spdt controller. Use series 40 or 80 for single controller to control multiple valves.

Figures 4, 5, 6 and 7 show wiring connections. Port "A" *open* and *closed* denote valve open and closed positions respectively. On auxiliary switch models, terminal 4 (grey wire) contact makes at the end of the Port A opening stroke. On Molex connector models, valve & auxiliary switch boltage must be the same to meet approval requirement. For mixed line voltage and 24 VAC (Safety Extra Low Voltage) application, the cable version is recommended.



CAUTION:

Disconnect power supply before connecting wiring to prevent electrical shock and equipment damage.

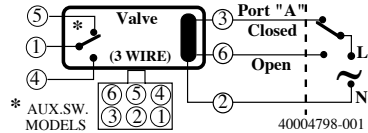

Figure 4 - Wire configuration for MOLEX™ models for SPDT controller. (Series 20 & 60).

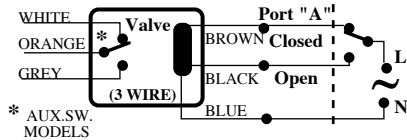

Figure 5 - Wiring color code for cable models for SPDT controller. (Series 20 & 60)

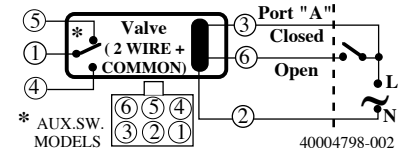

Figure 6 - Wire configuration for MOLEX™ models for SPST controller. (Series 40 & 80)

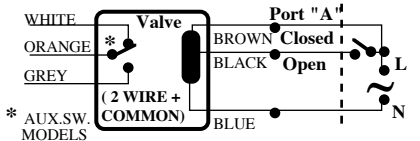

Figure 7 - Wiring color code for cable models for SPST controller. (Series 40 & 80)

OPERATION

Actuator Type	Connection		Valve Movement
	Cable Model	Molex™ Model	
3-WIRE (for SPDT controller)	Blue & Brown energised Black de-energised	Pin #2 & #3 energised Pin #6 de-energised	Closes
	Blue & Black energised Brown de-energised	Pin #2 & #6 energised Pin #3 de-energised	Opens
2 + COM. (for SPST controller)	Blue & Brown energised Black open	Pin #2 & #3 energised Pin #3 & #6 open	Closes
	Blue & Brown energised Black closed	Pin #2 & #3 energised Pin #3 & #6 closed	Opens

WHEN USED WITH SPDT (3-WIRE) CONTROLLER (Figure 8): On a call for heat, the NO thermostat contacts close, the valve opens. When the valve reaches the fully open position, the cam actuated SW1 closes and SW2 opens. When the need for heat is satisfied the NC thermostat contacts close, energizing the valve through SW1 to close the valve. When the valve reaches the fully close position, the cam actuated SW2 closes and SW1 opens anticipating the next call for heat cycle.

In a power failure the valve will stay at whatever position it was in when the power was interrupted. When power is restored, the valve will respond to the controller demand.

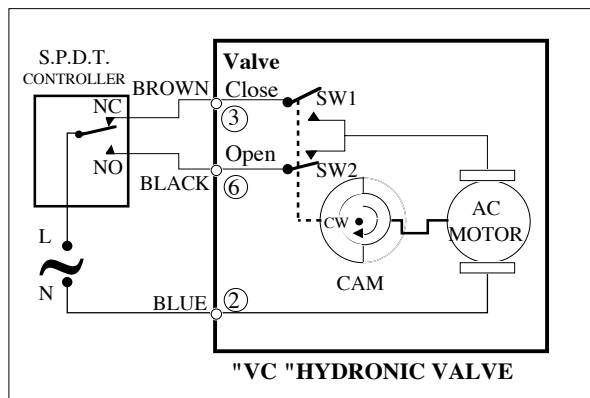

Figure 8 - Actuator wiring for SPDT controller (Series 20 and 60).

NOTE: VC2114 and VC8114 actuators must be used with separately-powered (hardwired) electronic controllers. Their sustained current draw is too low for power stealing (parasitic power) thermostats or series anticipators of electromechanical thermostats.

WHEN USED WITH SPST CONTROLLER (Figure 9): On a call for heat, RLY1 is energized making the NO contacts in SW3, the valve opens. When the valve reaches the fully open position the cam operated SW1 closes and SW2 opens. When need for heat is satisfied,

the thermostat contacts open, RLY1 is de-energized and the valve motor is driven closed through SW1 and the NC contacts of SW3. When the valve reaches the fully closed position, the cam operated SW2 closes and SW1 opens anticipating the next call for heat cycle.

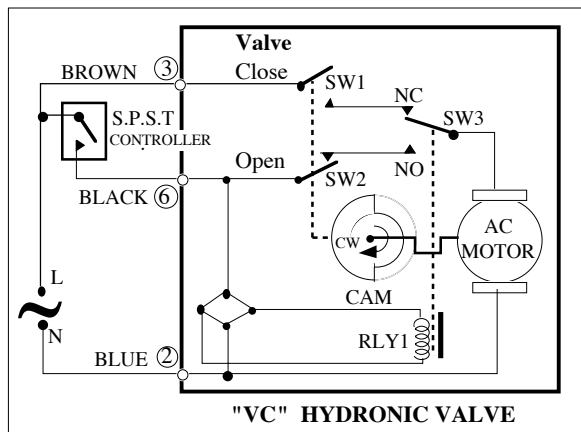

Figure 9 - Actuator wiring for SPST controller (Series 40 and 80).

CHECKOUT

1. Raise the set point of the thermostat above room temperature to initiate a call for heat. Red valve position lever should move downward to the open position.
2. For auxiliary switch models, observe all control devices. The valve should open and the auxiliary switch (if present) should close and make at the end of the opening stroke to activate auxiliary equipment.
3. Lower the set point of the zone thermostat below room temperature.
4. Observe the control devices. The valve should close and all auxiliary equipment should stop.

SERVICE

This valve should be serviced by a trained, experienced service technician.

1. If the valve is leaking, drain system **OR** isolate valve from the system.
2. Check to see if the cartridge needs to be replaced.
3. If the motor or other internal parts of the actuator is damaged, replace the entire actuator assembly.

NOTE: Honeywell hydronic valves are designed and tested for silent operation in properly designed and installed systems. However, water noises may occur as a result of excessive water velocity. Piping noises may occur in high temperature (over 212°F [100°C]) systems with insufficient water pressure.

By using this Honeywell literature, you agree that Honeywell will have no liability for any damages arising out of your use or modification to, the literature. You will defend and indemnify Honeywell, its affiliates and subsidiaries, from and against any liability, cost, or damages, including attorneys' fees, arising out of, or resulting from, any modification to the literature by you.

**Automation and Control Solutions
Environmental Control Products**
1985 Douglas Drive North
Golden Valley, MN 55422-3992
U.S.A.

In Canada:
Honeywell Limited-Limitee
35 Dynamic Drive
Toronto, ON M1V 4Z9
Canada

Honeywell

Printed in Canada