

TR21-WS, TR23-WS, TR21-WK, TR23-WK, WRECVR

INSTALLATION INSTRUCTIONS



FEATURES

- Wall module to Receiver (point to point) wireless kits can replace any standard wired sensor
- Wireless Kits (wall module and receiver) are pre-bound at the factory for quick installation
- Signal Strength LED built into the wall module
- Low battery indication
- Optional dip switches available to bind any wall module to any receiver
- Approximate 5 year battery life with AA Alkaline (included), 7.5 year with Lithium
- Locking screw discourages tampering and battery theft.

APPLICATION

The WRECVR receiver and TR21-WS, TR23-WS, TR21-WK, and TR23-WK are a family of wireless wall modules and receiver for use with:

- Spyder Unitary Controllers: PUL, PVL, etc.
- Excel 10 W7750, W7751, W7752, and W7753 controllers
- T7350, T7351, and TB8575 low-voltage SuitePRO™ thermostats
- Will not work with TB7220, TB8220 or TB line voltage thermostats, XL15s, W7762, W7763 or certain other XL controllers,
- Will work with WEBs-AX™ I/O Module products if using a separate transformer
- Compatibility with various other non-Honeywell controllers that accept 10K type2 NTC temperature inputs

NOTE: Refer to the *TR21 and TR23 Wall Modules – Specification Data*, form 63-1332, for specific model features and additional information.

SPECIFICATIONS

Models: For specific model information, see *Specification Data*, form 63-1332.

Environmental Ratings:

- Wall Module Operating Temperature: 45° to 99°F (7° to 37°C).
- Receiver Operating Temperature: -40° to 150°F (-40° to 65.5°C).
- Storage Temperature: -40° to 150°F (-40° to 65.5°C).
- Operating Humidity: 5% to 95% RH (non-condensing)

Accuracy: +/- 1°F (+/- 0.5°C) across 12°C to 30°C

Setpoint Range for TR23: 56° to 84°F (13° to 29°C)

Accessories: 50007298-001 (pack of 12) medium, cover plate; 6-7/8 x 5 in. (175 x 127 mm).

Power:

Receiver Voltage: 20 – 30VAC/DC, 50/60Hz; 24VAC typical

Housing:

- Wall Module: UL94-HB
- Receiver: UL94-5VA

Radio Frequency 2.4 GHz (IEEE Std 802.15.4-2003 compliant)

- Open Range: 3000 feet
- Typical Range: 100 feet
- Output power: 16dBm
- Receiver power consumption: <1.5 VA@24VAC

Model No.	FCC/IC ID's
TR21-WS	FCC ID: HS9WLKFWM IC: 573R-WLKF
TR21-WK	
TR23-WS	
TR23-WK	
TR21-WSU	
TR23-WSU	FCC ID: HS9WLKFRV IC: 573R-WLKF
WRECVR	
WRECVRU	



"Este equipamento opera em caráter secundário, isto é, não tem direito à proteção contra interferência prejudicial, mesmo de estações do mesmo tipo, e não pode causar interferência a sistemas operando em caráter primário."



62-0291-09

Approximate battery life under normal operating conditions:

- 5 years with two AA Alkaline batteries (included)
- 7.5 years with two AA Lithium Batteries

Transmission interval: 30 seconds

Pressing override button or signal strength button will force an immediate transmission.

Approvals:

This device complies with Part 15 of the FCC rules. Operation is subject to the following two conditions:

- 1) this device may not cause harmful interference, and
- 2) this device must accept any interference received, including interference that may cause undesired operation.

INSTALLATION



CAUTION

Erratic System Operation Hazard.

Failure to follow proper wiring practices can introduce disruptive electrical interference (noise). Keep wiring at least one foot away from large inductive loads such as motors line starters, lighting ballasts, and large power distribution panels.

Shielded cable is required in installations where these guidelines cannot be met.

Ground shield only to grounded controller case.

IMPORTANT

All wiring must comply with local electrical codes and ordinances or as specified on installation wiring diagrams.

- Receiver wiring can be sized from 16 to 22 AWG (1.31 to 0.33 sq. mm) depending on the application.
- The maximum length of wire from a device to a receiver is 100 ft. (30.5 m).

Mounting the Receiver

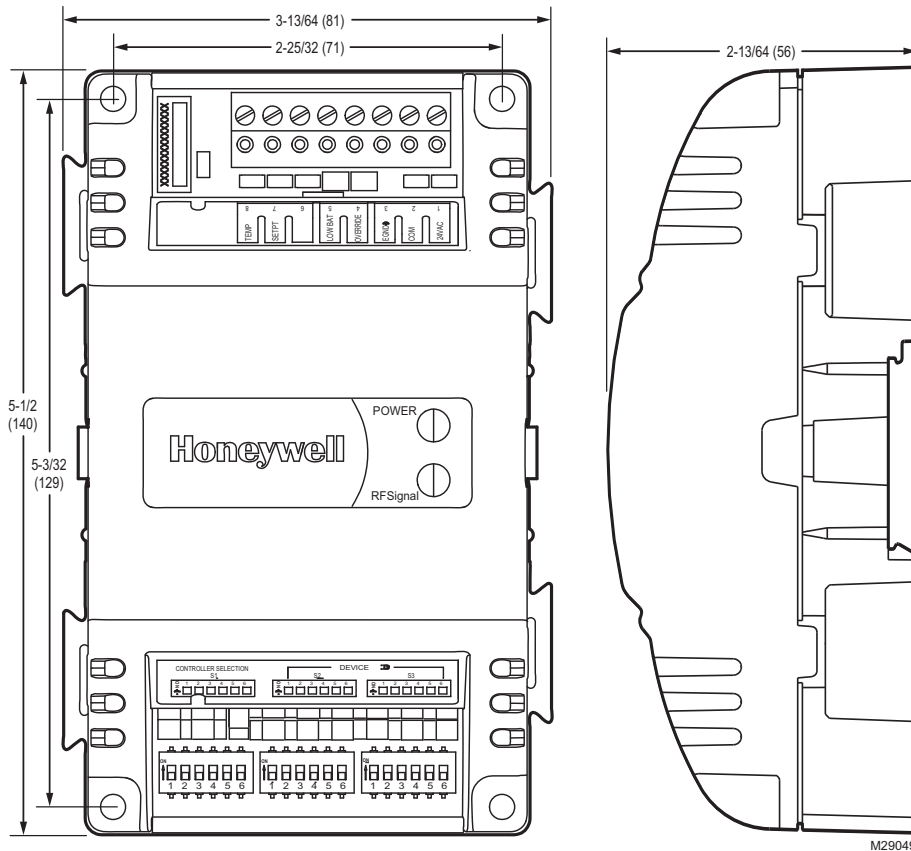

Fig. 1. Receiver dimensions in in. (mm).

The receiver can be mounted on any surface using screws (No. 6 or No. 8) appropriate for the mounting surface. The receiver can also be mounted to the Spyder controller using the mounting slots and tabs (dovetails), and can be mounted to a DIN rail.

Mounting the Wall Module

Mount the wall module on an inside wall approximately 54 in. (1372 mm) from the floor (or in the specified location) to allow exposure to the average zone temperature. Do not mount the wall module on an outside wall, on a wall containing water pipes, or near air ducts. Avoid locations that are exposed to discharge air from registers or radiation from lights, appliances, or the sun. When mounting to drywall, use the horizontal mounting screw locations, as shown in Fig. 3.

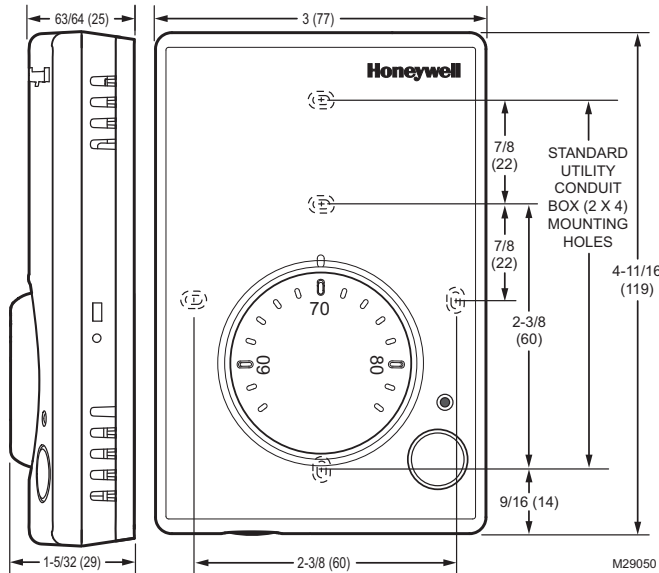

Fig. 2. Wall Module subbase dimensions in inches (mm) (TR23 shown).

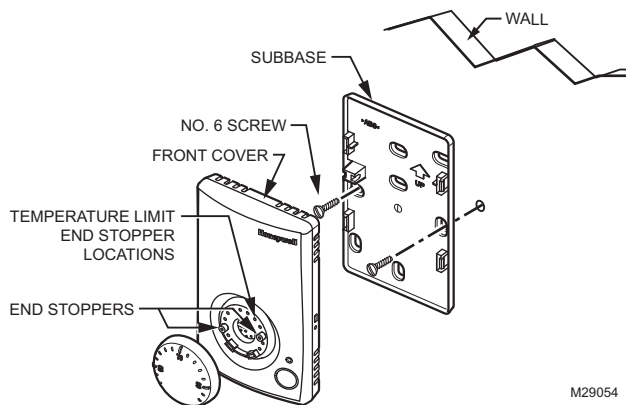

Fig. 3. Mounting the wall module on the wall and temperature limit set screw locations (TR23 shown).

There is a locking screw option to prevent tampering and access to batteries. The screw is provided with the wall module, and screws into the slot shown in Fig. 9 after the device is snapped onto the subbase.

If desired, insert the two red end stoppers into temperature scale to set the desired temperature range limit. See Fig. 3.

For TR23 models, insert the desired dial through the opening in the cover. Align the keyed shaft on the knob with the keyed slot into the fitting on the subbase, then press down until it snaps into place.

WIRING

Attach the wires from the device terminals to the appropriate receiver terminals.

! CAUTION

Improper Electrical Contact Hazard.
Screw type terminal blocks are designed to accept no more than one 16 AWG (1.31 sq. mm) conductor.

Connect multiple wires that are 16-18 AWG (1.31-0.82 sq. mm) with a wire nut. Include a pigtail with this wire group and attach the pigtail to the individual terminal block.

Wire the terminal block as follows:

1. For single wires, strip 3/16 in. (5 mm); for multiple wires going into one terminal, strip 1/2 in. (13 mm) insulation from the conductor.
2. If two or more wires (18 to 22 AWG only) are being inserted into one terminal, twist the wires together before inserting.

NOTE: When two or more wires are being inserted into one terminal, be sure to twist them together. Deviation from this rule can result in improper electrical contact. See Fig. 4.

3. Insert the wire in the required terminal location and tighten the screw to complete the termination.
4. Review and verify the terminal connection wiring and DIP switch settings.

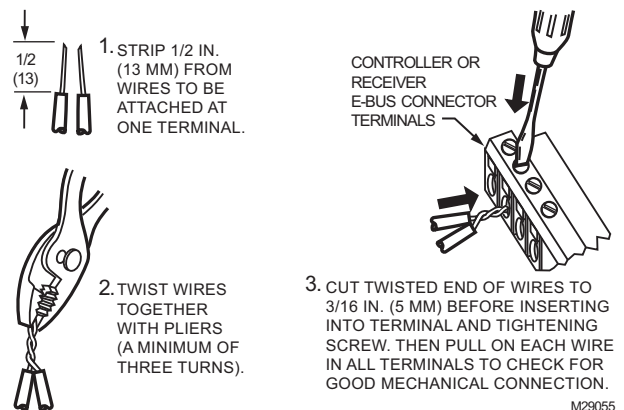

Fig. 4. Attaching two wires (18 to 22 AWG) to receiver terminals.

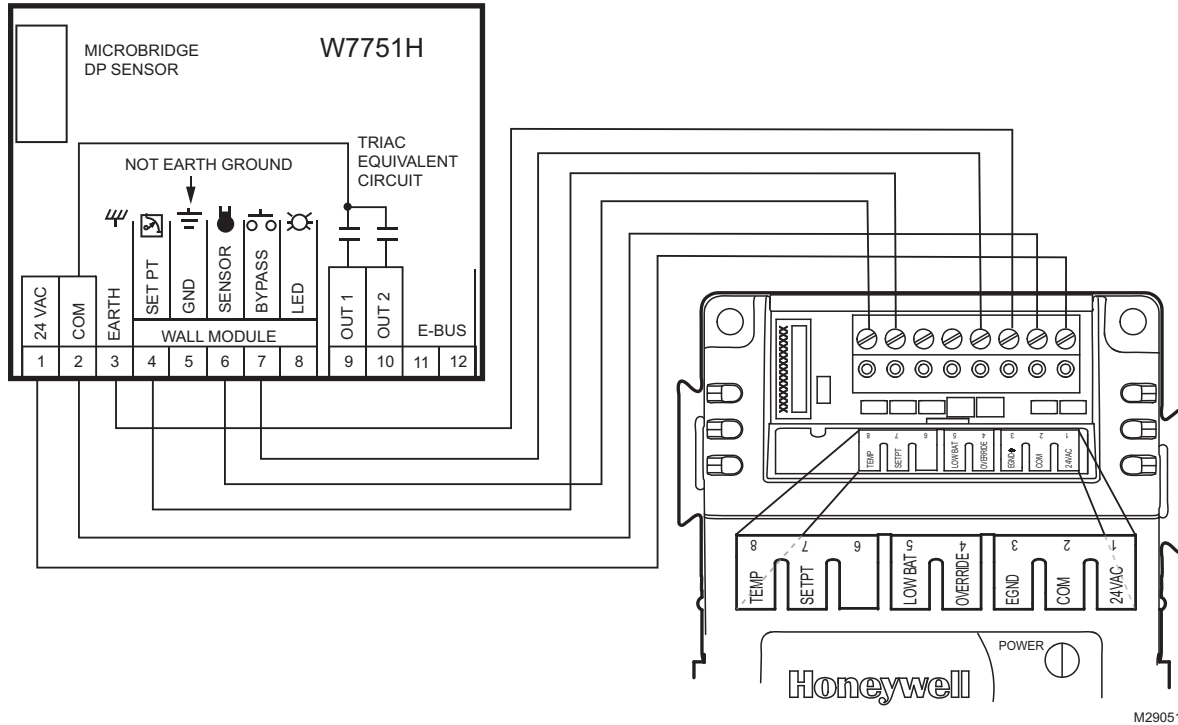

Fig. 5. Wiring receiver to Excel 10.

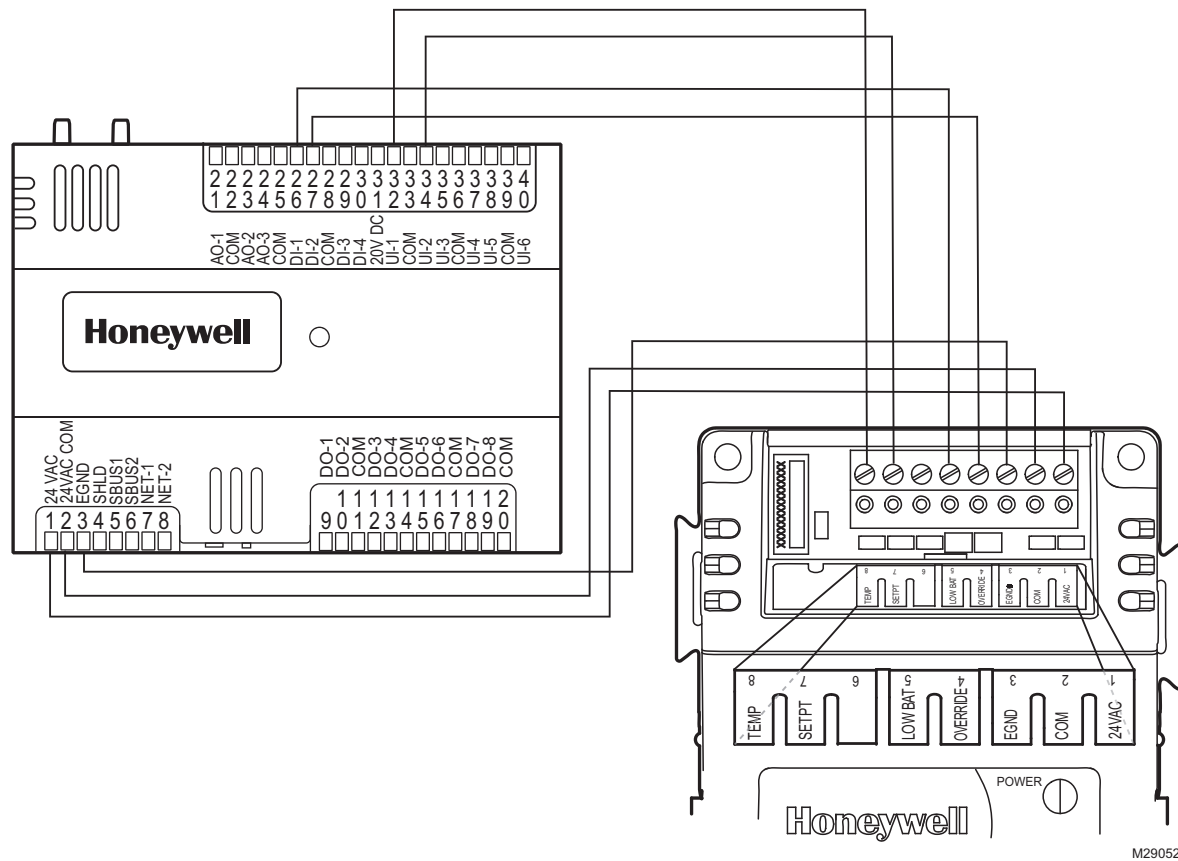

Fig. 6. Wiring receiver to Spyder Unitary Controller.

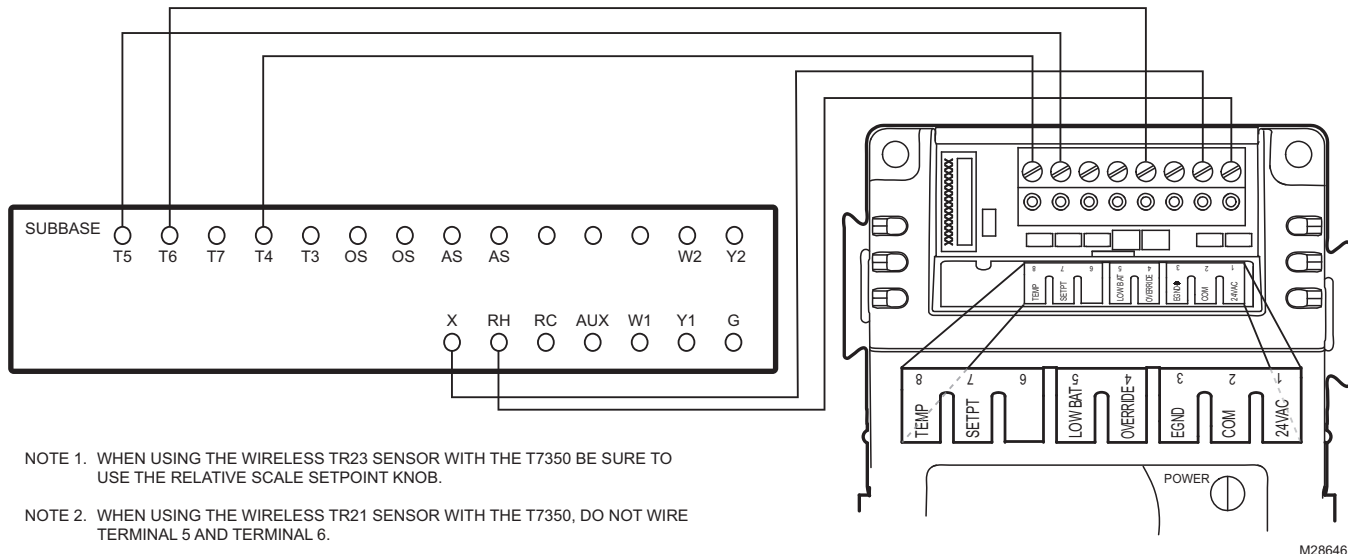

Fig. 7. Wiring receiver to T7350 thermostat.

DIP Switch Labels

This device is packed with tear-off DIP switch labels you can attach to the receiver and indicate which DIP switches are on and off.

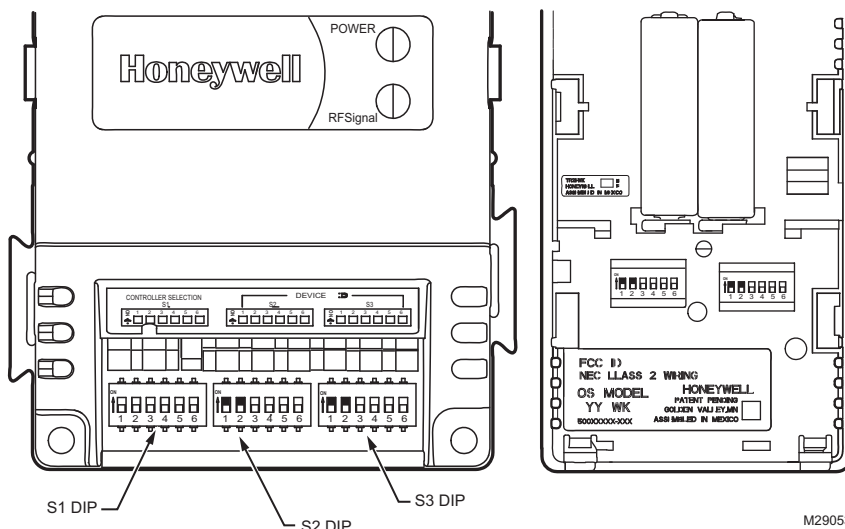

Fig. 8. Wall module DIP switches and Receiver DIP switches S1, S2, and S3. Figure shows an example of sensor DIP switches matching S2 and S3 DIP switches on receiver.

TESTING FOR SIGNAL STRENGTH

When the receiver is powered and batteries are placed in the wall module, communication will begin automatically within 2 seconds. The receiver RF signal light will flash every 30 seconds to confirm each transmission. You can force immediate communication by pressing the signal strength button on the side of the wall module with a 1-1.6 mm

diameter probe with flat or rounded face (a common paperclip will do) (see Fig. 9). This may be required to initiate communication when replacing a wall module.

The signal strength LED next to the signal strength button will light up on the side to show the relative signal strength. The signal strength LED will initially light amber when the signal strength button is pressed to verify that you are pressing the signal strength button. When you release the signal strength button, the light will behave as shown in Table 1.

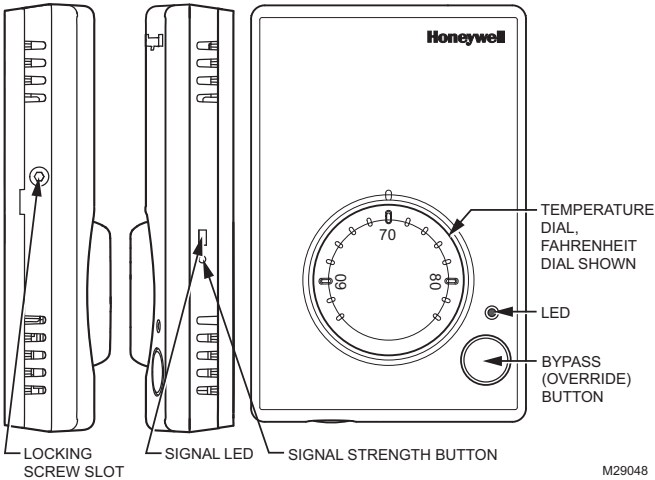

Fig. 9. Wall module features (TR23 shown).

Table 1. Signal Strength LED.

LED	Signal Strength
Remains Green for 5 seconds	Strong
Remains Amber for 5 seconds	Weaker (still acceptable)
Amber blinks for 5 seconds	No signal

If no signal is received, test the wall module in a different location until a suitable signal strength is received by the receiver. Pressing the signal strength button on the wall module will cause a five-second flash on the RF signal LED on the receiver, and pressing the override button will cause a single flash on the receiver.

In normal operation, the sensor transmits to the receiver every 30 seconds. If the receiver fails to receive a signal after 15 attempts (7.5 minutes), the receiver will try to re-establish communication every minute for 8 consecutive minutes. During this time (maximum 15.5 minutes) the receiver will continue to output the last valid temperature value it received from the sensor. If there is no valid signal received after 15.5 minutes, the receiver will simulate an open circuit (like a cut wire on a wired sensor) and go into a sleep mode. Thereafter, every ten minutes, the receiver will try to re-establish signal.

BINDING THE WALL MODULE AND RECEIVER TO EACH OTHER

The TR21-WK and TR23-WK wireless kits include a wall module and receiver that have already been bound in the factory to automatically communicate with each other. They can be identified as matching by the identical bind numbers printed on the labels. The S2 and S3 DIP switches on the receiver (used to bind the two devices) and the 12 DIP switches on the wall module will all be in the OFF position. As soon as power is applied to the receiver and the batteries are installed in the wall module, the two devices start to talk to

each other. If the two devices don't communicate immediately, remove and re-install one battery, leaving it out for 10 seconds OR you can initiate communication by pressing the signal strength button on the sensor (using paperclip).

Each wireless kit has a unique binding, so even though multiple wireless kits have S2 and S3 switches all in the OFF position, each device will only communicate to the device to which it was paired and shipped as a kit.

There may be times when you want to bind a receiver to a wall module using the DIP switches. This is done simply by matching any S2/S3 DIP switch settings on the receiver with the DIP switch settings on the wall module. Wall modules in close proximity must have different DIP switch settings (except when modules are using the all-OFF default binding).

DIP switches S2/S3 are provided for two reasons:

- If the wall module needs to be replaced, a TR21-WS or TR23-WS wall module can be purchased. To bind any wall module and receiver, simply set the DIP switches S2/S3 on both the receiver and the wall module to any matching DIP configuration. To prepare for this ahead of time, the receiver and wall module in the WK kit can be set with a matching dip switch configuration when mounted. The tear off tab on the receiver allows the installer to write down the on/off DIP configuration. Then the new wall module's DIP switches can be set by matching the old wall module's DIP switches, without having to set or check the DIP switches on the receiver.
- If wall modules and receivers get mixed up in the field (even though they are marked with matching numbers from the factory), DIP switches can be used to bind any wall module to any receiver simply by matching the S2/S3 DIP switches. If setting DIP switches, be sure that each wireless sensor/receiver pair in a given building has a unique DIP switch setting to prevent cross-talk.

Fig. 8 shows matching DIP switch settings binding the wall module and receiver.

Controller Matching

The TR21 and TR23 wireless wall modules can be used with many different controllers. The S1 switch on the receiver can be set for a number of different controller requirements. See Table 2 for DIP switch settings, and see Table 3 for a description of the controller.

Table 2. S1 DIP Switch Settings.

	Controller	S1 DIP Switches					
		1	2	3	4	5	6
1.	Spyder/ComfortPoint 20Kohm, XL10	ON	OFF	OFF	OFF	OFF	OFF
2.	XL600, 500, 100, 80	OFF	ON	OFF	OFF	OFF	OFF
3.	10K type 2, 3-wire	ON	ON	OFF	OFF	OFF	OFF
4.	10K type 2, see I&I	OFF	OFF	ON	OFF	OFF	OFF
5.	10K type 2, 4-wire	ON	OFF	ON	OFF	OFF	OFF
6.	10K type 2, 3-wire	OFF	ON	ON	OFF	OFF	OFF

Table 3. Controller Descriptions.

	Controller	Description
1.	Spyder/ComfortPoint 20Kohm, XL 10	Default setting. For use with Spyder and Comfort Point 20K ohm controllers For use with XL10 VAV, W7750, W7751, etc.
2.	Honeywell Other	For use with XL600/500/100.
3.	10K type 2	10K ohm NTC type 2 output, 2K-3K ohm knob span: <ul style="list-style-type: none"> • Common • Temperature (Override button temporarily shorts the temperature output) • Setpoint
4.	10K type 2	10K ohm NTC type 2 output, 1K -11K ohm knob span.
5.	10K type 2	10K ohm NTC type 2 output, 0-10K ohm knob span: <ul style="list-style-type: none"> • 10K out • Common (for temperature, override, and setpoint) • Override • Setpoint
6.	10K type 2 (ComfortPoint 10K ohm controllers)	10K ohm NTC type 2 output, 0-9500 ohm knob span: <ul style="list-style-type: none"> • Common • Temperature (Override button temporarily shorts the temperature output) • Setpoint

Low Battery Signal

When there are approximately 2 months of battery life remaining, the LED on the front of the wall module (next to the Override button) will flash red every 15 seconds. In addition, the LOW BAT digital output from the receiver will close. This LOW BAT output signal can be sent to an unused DI on the controller to let the user know that there is a low battery condition. Replace the batteries whenever the LOW BAT contact closes, or flashing red light is seen next to the Override LED on the face of the wall module. Normal operation will automatically resume.

NOTE: If the batteries go dead, the LOW BAT digital output (open/close) signal will open again. The LOW BAT digital output will close only when batteries are running low, not when they are completely dead, or are not installed. This ensures that a lack of signal is not confused with dead or missing batteries. Whenever there is no signal, or batteries have gone completely dead, the receiver LOWBAT output will send an open circuit reading to the controller for temperature (and set point, if applicable).

Override Button

To save battery life, the override button LED will only light when the button is pressed. It will not remain lit, as on standard wired TR23 and TR24 models. Override will still be activated when the button is pressed. If using with the XL10, pressing and briefly holding the override button will cause it to behave like other standard wired TR23s. The LED will remain lit for 9 seconds max. to confirm it has been pressed from 1-4 seconds.

REPLACING A WALL MODULE

When replacing a wall module, set the DIP switches the same as the wall module being replaced. If the previous wall module DIP switches are all set to OFF, it will be necessary to reset the S2 and S3 receiver dip switches to any configuration not

being used by other receivers in the area, and then set the wall module DIP switches to the same setting. At least one of the 12 DIP switches must be set to the ON (up) position.

General Rules for Installing Wireless Wall Modules

Communication between the wall module and receiver can be influenced by a number of factors. Type and thickness of building materials and the way in which they are oriented in relation to the wall module and receiver will affect communication. Try to orient the wall module and receiver so that if they are separated by a wall(s), the direction of signal travel is as perpendicular to the wall(s) as possible. This reduces the effective wall thickness.

Do not place either the wall module or receiver inside metal cabinets or enclosures. Signal reliability can be diminished if the receiver is installed in metal fan coil units. Older buildings may have plaster and lathe walls with metal mesh that can significantly reduce signal strength.

When mounting the receiver on a metal duct, stronger communication is possible if the wall module is on the same side of the duct so the signal doesn't need to travel through the metal duct.

Standard drywall (gypsum board) does not greatly affect signal strength.

Be aware that occasional signal drop outs may occur in any wireless installation, and the controller must be able to accommodate for sensor and setpoint outputs from the receiver that may occasionally go into a brief open circuit mode. Reduce as much as possible the amount of metal (ducts, file cabinets, etc.) between and around the sensor and the wall module.

For the most robust wireless link, install the wall module in locations with the strong signal (Green light as described in Table 1). While the signal may appear green at any given moment, movement of people, repositioning of furniture or

TR21-WS, TR23-WS, TR21-WK, TR23-WK, WRECVR

other structures (especially when made of metal), or the presence of other strong radio signals may cause temporary and/or frequent functional disruption of the wireless signal.

The TR21-WK and TR23-WK have been successfully employed in hundreds of different locations and applications. However, because of the variability of various environments, Honeywell cannot guarantee that these wireless kits will work successfully in every application, even when a green signal strength is indicated on initial installation. Although no standalone diagnostics tools are available for the TR wireless products, the self-diagnostics and LED indicators on the wall module and receiver do provide a reliable indication of signal strength at any given point in time.

LonWorks® is a registered trademark of Echelon® Corporation.

LonMark® and the LonMark Logo are trademarks of the LonMark Association.

Automation and Control Solutions

Honeywell International Inc.
1985 Douglas Drive North
Golden Valley, MN 55422

Honeywell Limited-Honeywell Limitée
35 Dynamic Drive
Toronto, Ontario M1V 4Z9
customer.honeywell.com

By using this Honeywell literature, you agree that Honeywell will have no liability for any damages arising out of your use or modification to, the literature. You will defend and indemnify Honeywell, its affiliates and subsidiaries, from and against any liability, cost, or damages, including attorneys' fees, arising out of, or resulting from, any modification to the literature by you.

Honeywell

© U.S. Registered Trademark
© 2011 Honeywell International Inc.
62-0291—09 M.S. Rev. 01-11
Printed in U.S.A.