

205830A Crankarm Kit for Direct Coupled Rotary Actuators

INSTALLATION INSTRUCTIONS

APPLICATION

This document provides installation instructions for the 205830A Crankarm Kit for Direct Coupled Rotary Actuators.

INSTALLATION

Equipment Needed

- Hex wrench for 8 mm set screws.

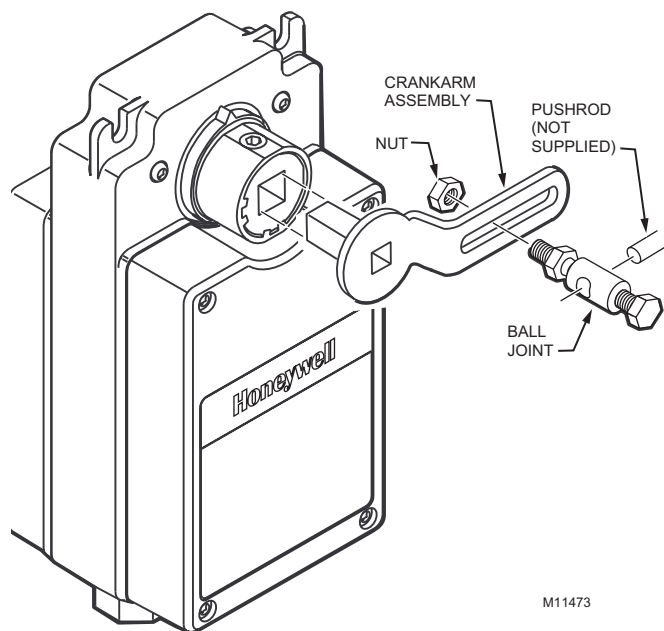

Fig. 1. Attaching the 205830A Crankarm Kit to the actuator.

Instructions

NOTE: Refer to the Damper Parts and Accessories section of the Honeywell TRADELINE® Catalog for parts not included with the crankarm kit. The parts listed in the procedure below are identified with an asterisk (*).

1. Slide the crankarm assembly into the actuator output hub (see Fig. 1) and secure with the two 8 mm hub set screws. Maximum tightening torque is 100 lb-in.
2. Slip the damper crankarm* on the damper shaft. Make sure that the damper blades are in the actuator off or minimum position.
3. Tighten the damper crankarm set screws finger tight. Further adjustment will be needed later.
4. Install one ball joint at the innermost position of the actuator crankarm, and the other at the desired angular degrees-of-travel on the damper crankarm. (Damper crankarm travel will be approximately half of that indicated on the damper crank arm.) On uncalibrated damper crankarms, estimate the correct ball joint position and adjust later.
5. Slide the pushrod* through the two ball joints and tighten the ball joint screws finger tight.
6. Make final adjustments and securely tighten all set screws.



Honeywell

Automation and Control Solutions

Honeywell International Inc.	Honeywell Limited-Honeywell Limitée
1985 Douglas Drive North	35 Dynamic Drive
Golden Valley, MN 55422	Scarborough, Ontario
	M1V 4Z9

