

V8200, VR8200, VR8201 Continuous Pilot Combination Gas Controls

INSTALLATION INSTRUCTIONS

APPLICATION

These continuous pilot combination gas controls are used in gas-fired appliances that have up to 200 cfm capacity of natural gas. They include safety shutoff, a manual valve, a pressure regulator and pilot adjustment. The V8200 has a single automatic operator, except for the V8200F, which, like the VR8200, has two automatic operators. The VR8201 has two independently controlled automatic operators. Body pattern is straight-through with 1/2 in. inlet and 1/2 in. outlet. Some models include two optional 1/4 in. quick-connect convenience terminals.

See Table 1 for differences between models, and Table 2 for temperature ranges and regulator types. If a 7 follows the suffix letter in the model number (e.g., V8200A7001), the unit includes an electrical cut-off (ECO) connector with two 1/4 in. quick-connect terminals.

Angle and straight adapters are available for 3/8, 1/2 and 3/4 in. pipe. See Table 3 for adapter part numbers. Flange kits include one flange with attached O-ring, four mounting screws, a 9/64 in. hex wrench and instruction sheet.

IMPORTANT

Controls are factory-set for natural (and manufactured) or LP gas. Do not attempt to use a control set for natural (manufactured) gas on LP gas, or a control set for LP on natural (manufactured) gas.

Controls with standard or slow opening regulators can be converted from one gas to the other with a conversion kit (ordered separately). Order conversion kit part no. 393691 to convert from natural (manufactured) to LP gas; order conversion kit part no. 394588 to convert from LP to natural (manufactured) gas. Controls with step opening regulators cannot be converted. Controls with unregulated step openings (V8200F) are convertible.

Table 1. Continuous Pilot Combination Gas Control Models.

Model	Voltage/Frequency	Number of Automatic Operators	Gas Control Knob Positions	Current Draw (Amps)
V8200	24 Vac/60 Hz	One	OFF-PILOT-ON	0.335
VR8200/V8200F ^a	24 Vac/60 Hz	Two	OFF-PILOT-ON	0.5
VR8201	24 Vac/50/60 Hz	Two, Independently Controlled	OFF-PILOT-ON	0.5

^a V8200F is a non-redundant valve due to a step bypass orifice.

Table 2. Model Number Suffix Letter Designation.

Model No. Suffix Letter	Ambient Temperature Range	Regulator Type
A	0°F to 175°F (-18°C to +79°C)	Standard
C		Step-opening
F		Unregulated step-opening
H		Slow-opening
K	-40°F to +175°F (-40°C to +79°C)	Standard
M		Standard
P		Step-opening

Table 3. Flange Part Numbers.

Inlet/Outlet Pipe Size (NPT)	Flange Type	Part Number	
		With Hex Wrench	Without Hex Wrench
3/8 in.	Straight	393690-1	393690-11
	Elbow ^a	393690-2	393690-12
1/2 in.	Straight	393690-6	393690-16
	Elbow ^a	393690-3	393690-13
3/4 in.	Straight	393690-4	393690-14
	Elbow ^a	393690-5	393690-15

^a Elbow (angle) flanges cannot provide right hand inlet when the ECO connector is used.



CAUTION

Equipment Damage Hazard. **Improper installation can cause equipment damage.**

The V8200F is not functionally equivalent to other V8200 models and they should not be used interchangeably. The V8200F is a non-redundant valve and is not suitable for applications that require dual shutoff valves. If the application requires a redundant shutoff function, a VR8200 Valve should be used. The V8200F includes a step-opening feature. Use of a valve with non-step opening characteristics could produce a rough light-off, resulting in nuisance shutdowns or possible damage to the appliance.

NOTE: Flange kits include one flange with attached O-ring and four mounting screws. TRADELINE® kits include a 9/64 in. hex wrench, as noted.

Approvals:

American Gas Association Design Certificate:
UP-70-57A.

Canadian Gas Association Design Certificate:
1029-CC-8375.

Australian Gas Association Design Certificate: 4214.
Approved for Delta C applications.

PLANNING THE INSTALLATION

WARNING

Fire or Explosion Hazard. **Can cause property damage, serious injury or death.**

Follow these warnings exactly:

1. Review the installation as outlined in this section.
2. Plan for frequent maintenance as described in the Maintenance section.

When gas controls are used on heating appliances such as commercial cookers, agricultural equipment, industrial heating equipment and pool heaters, heavy demands are made on the controls. Special steps may be required to prevent nuisance shutdowns and control failure due to frequent cycling and severe environmental conditions related to moisture, corrosive chemicals, dust or excessive heat. These applications require Honeywell Environmental and Combustion Controls Engineering review; contact your Honeywell Sales Representative for assistance.

Review the following conditions that may apply to your specific installation and take the precautionary steps suggested.

Frequent Cycling

These controls are designed for use on appliances that typically cycle only three to four times an hour during the heating season. In year-round applications with greater cycling rates, the control can wear out more quickly. Perform a monthly checkout.

Water or Steam Cleaning

If a gas control gets wet, replace it. If the appliance is likely to be cleaned with water or steam, protect (cover) the controls and wiring from water or steam flow. Mount the controls high enough above the bottom of the cabinet to avoid getting wet during normal cleaning procedures. NEMA 4 enclosure is recommended for the ignition module; see the Electronic Ignition Service Handbook, form no. 71-97927.

High Humidity or Dripping Water

Dripping water can cause the module to fail. *Never* install an appliance where water can drip on the controls.

In addition, high ambient humidity can cause the gas control to corrode and fail.

If the appliance is in a humid atmosphere, make sure air circulation around the controls is adequate to prevent condensation. Also, regularly check out the system. NEMA 4 enclosure is recommended for the ignition module; see the Electronic Ignition Service Handbook, form no. 71-97927.

Corrosive Chemicals

Corrosive chemicals can attack the module and gas control, eventually causing a failure. If chemicals are used for routine cleaning, avoid contact with the controls. Where chemicals are suspended in air, as in some industrial or agricultural applications, NEMA 4 enclosure is recommended for the ignition module; see the Electronic Ignition Service Handbook, form no. 71-97927.

Dust or Grease Accumulation

Heavy accumulations of dust or grease can cause controls to malfunction. Where dust or grease can be a problem, provide covers for the module and the gas control to limit contamination. NEMA 4 enclosure is recommended for the ignition module; see the Electronic Ignition Service Handbook, form no. 71-97927.

Heat

Excessively high temperatures can damage controls. Make sure the maximum ambient temperature at the control does not exceed the rating of the control. If the appliance operates at very high temperatures, use insulation, shielding, and air circulation, as necessary, to protect the controls. Proper insulation or shielding should be provided by the appliance manufacturer; verify proper air circulation is maintained when the appliance is installed.

INSTALLATION

When Installing This Product...

1. Read these instructions carefully. Failure to follow them could damage the product or cause a hazardous condition.
2. Check the ratings given in the instructions and on the product to make sure the product is suitable for your application.
3. Installer must be a trained, experienced service technician.
4. After installation is complete, check out the product operation as provided in these instructions.

WARNING

Fire or Explosion Hazard.

Can cause property damage, serious injury or death.

Follow these warnings exactly:

1. Disconnect power supply before wiring to prevent electrical shock or equipment damage.
2. To avoid dangerous accumulation of fuel gas, turn off gas supply at the appliance service valve before starting installation, and perform Gas Leak Test after completion of installation.
3. Do not bend pilot tubing at gas control or pilot burner after compression fitting is tightened. Gas leakage at the connection may result.
4. Always install sediment trap in gas supply line to prevent contamination of gas control.
5. Do not force the gas control knob. Use only your hand to push down the reset button or turn the gas control knob. Never use any tools. If the gas control knob or reset button will not operate by hand, have a qualified service technician replace the control. Force or attempted repair may result in fire or explosion.

CAUTION

Equipment Damage Hazard.
Can cause property damage.

Never apply a jumper across or short the valve coil terminals. This can burn out the heat anticipator in the thermostat.

IMPORTANT

These gas controls are shipped with protective seals over inlet and outlet tapings. Do not remove seals until ready to connect piping.

Follow the appliance manufacturer instructions if available; otherwise, use the instructions provided.

Converting Between Natural and LP Gas

WARNING

Fire or Explosion Hazard.

Can cause property damage, severe injury or death.

1. Use a gas control set for natural (manufactured) gas only on a natural (manufactured) gas system. Use a gas control set for LP gas only on an LP gas system.
2. When making conversions, be sure main and pilot burner orifices are changed to meet appliance manufacturer specifications.

Gas controls with standard or delayed opening regulators can be converted between LP and natural gas. Gas controls with step opening regulators cannot be converted. Refer to appliance manufacturer instructions for orifice specifications and conversion procedures. Gas controls are factory-set for natural (manufactured) or LP gas. Do not attempt to use a control set for natural (manufactured) gas on a LP gas control, or a control set for LP gas on a natural (manufactured) gas control. Gas controls with step opening regulators cannot be converted.

Models Requiring Conversion Kit

Models with slotted pressure regulator cap, (see Fig. 5), require a conversion kit. Gas controls with standard or slow opening regulators can be converted from one gas to the other with a conversion kit (ordered separately). Order part no. 393691 to convert from natural (manufactured) to LP gas; order part no. 394588 to convert from LP to natural (manufactured) gas. Follow instructions provided with kit. Gas controls with step opening regulators cannot be converted.

Models with Convertible Pressure Regulators

Models with NAT or LP stamped on the pressure regulator cap (see Fig. 1), are convertible pressure regulator models.

To convert between natural and LP gas:

1. Check valve label and appliance manufacturer's rating plate to determine if the factory pressure regulator setting meets the appliance manifold requirement.
2. Check for letters NAT (natural manufactured gas) or LP (liquid petroleum gas) on the pressure regulator cap.
3. If the appropriate letters are not visible, remove the cap.
4. Invert cap until letters appear that represent the gas type selected.
5. Replace and tighten 1/4 turn past finger tight.

NOTE: Convertible pressure regulator models do not have field-adjustable regulators.

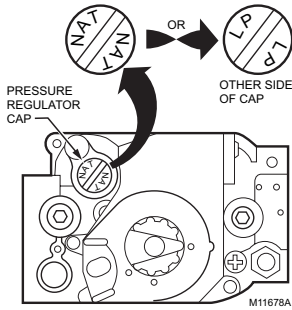

Fig. 1. Top view of convertible pressure regulator cap.

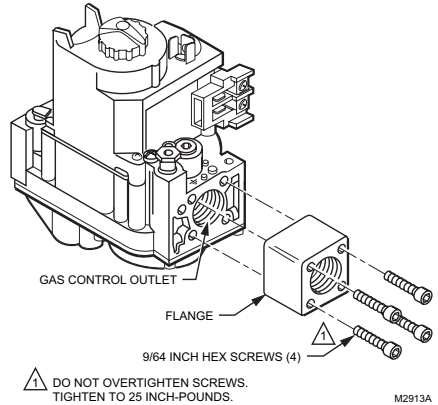

Fig. 2. Fasten flange to valve firmly, but do not overtighten screws.

Install Adapters to Control

If adapters are to be installed on the gas control, mount them as follows:

Flanges:

1. Choose the appropriate flange for your application.

NOTE: A right angle inlet flange cannot be used with the ECO connected.

2. Remove seal over gas control inlet or outlet.
3. ensure that the O-ring is fitted in the groove of the flange. If the O-ring is not attached or is missing, do not use the flange.
4. With O-ring facing the valve, align the screw holes on the control with the holes in the flange. Insert and tighten the screws provided with the flange. (See Fig. 2). Tighten the screws to 25 in. pounds (2.82 n-m) of torque to provide a gas-tight seal.

Bushings:

1. Remove seal over gas control inlet or outlet.
2. Apply moderate amount of good quality pipe compound to bushing, leaving two end threads bare. On LP installation, use compound resistant to LP gas. *Do not use Teflon tape.*
3. Insert bushing into control and thread pipe carefully until tight.

Complete instructions below for installing piping, installing gas control, connecting pilot gas tubing, connecting thermocouple and wiring. Make certain the leak test you perform on the control after completing the installation includes leak testing the adapters and screws. If you use a wrench on the gas control after flanges are installed, use the wrench only on the flange, not on the control.

Location

The combination gas control is mounted in the appliance vestibule on the gas manifold. If this is a replacement application, mount the gas control in the same location as the old control.

Do not locate the gas control where it may be affected by steam cleaning, high humidity, dripping water, corrosive chemicals, dust or grease accumulation, or excessive heat. To ensure proper operation, follow these guidelines:

- Locate gas control in a well-ventilated area.
- Mount gas control high enough above the cabinet bottom to avoid exposure to flooding or splashing water.
- Ensure the ambient temperature does not exceed the ambient temperature ratings for each component.
- Cover gas control if appliance is cleaned with water, steam, or chemicals to avoid dust and grease accumulation.
- Avoid locating gas control where exposure to corrosive chemical fumes or dripping water is likely.

Install Piping to Gas Control

All piping must comply with local codes and ordinances or with the National Fuel Gas Code (ANSI Z223.1 NFPA No. 54), whichever applies. Tubing installation must comply with approved standards and practices.

1. Use new, properly reamed pipe, free from chips. If tubing is used, ensure the ends are square, deburred and clean. All tubing bends must be smooth and without deformation.
2. Run pipe or tubing to the control. If tubing is used, obtain a tube-to-pipe coupling to connect the tubing to the control.
3. Install sediment trap in the supply line to the gas control. (See Fig. 3).

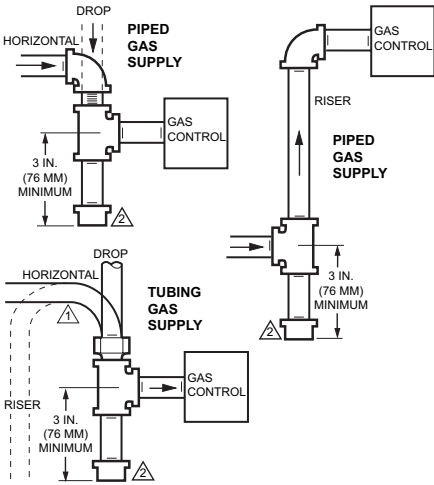

- ▲ ALL BENDS IN METALLIC TUBING SHOULD BE SMOOTH.
- ▲ CAUTION: SHUT OFF THE MAIN GAS SUPPLY BEFORE REMOVING END CAP TO PREVENT GAS FROM FILLING THE WORK AREA. TEST FOR GAS LEAKAGE WHEN INSTALLATION IS COMPLETE. M3077A

Fig. 3. Sediment trap installation.

Install Control

1. This control can be mounted 0 to 90 degrees, in any direction, from the upright position of the gas control knob, including vertically.
2. Mount the gas control so gas flow is in the direction of the arrow on the bottom of the control.
3. Thread pipe (the amount shown in Table 4) for insertion into the control. *Do not thread the pipe too far.* Valve distortion or malfunction may result if the pipe is inserted too deeply.

Table 4. NPT Pipe Thread Length.

Pipe Size (in.)	Thread Pipe this Amount (in.)	Maximum Depth Pipe can be Inserted Into Control (in.)
3/8	9/16	3/8
1/2	3/4	1/2
3/4	13/16	3/4

4. Apply a moderate amount of good quality pipe compound (do not use Teflon tape) to pipe only, leaving two end threads bare. On LP installations, use compound resistant to LP gas. (See Fig. 4).

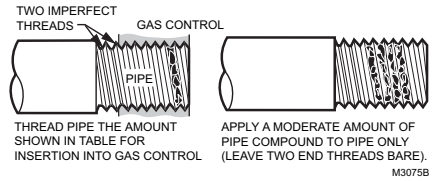

Fig. 4. Use moderate amount of pipe compound.

5. Remove seals over gas control inlet and outlet, if necessary.
6. Connect pipe to gas control inlet and outlet. Use wrench on the square ends of the control. If a flange is used, place wrench on the flange rather than on the control. (See Figures 5 and 6).

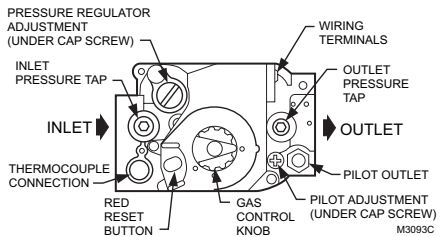

Fig. 5. Top view of gas control.

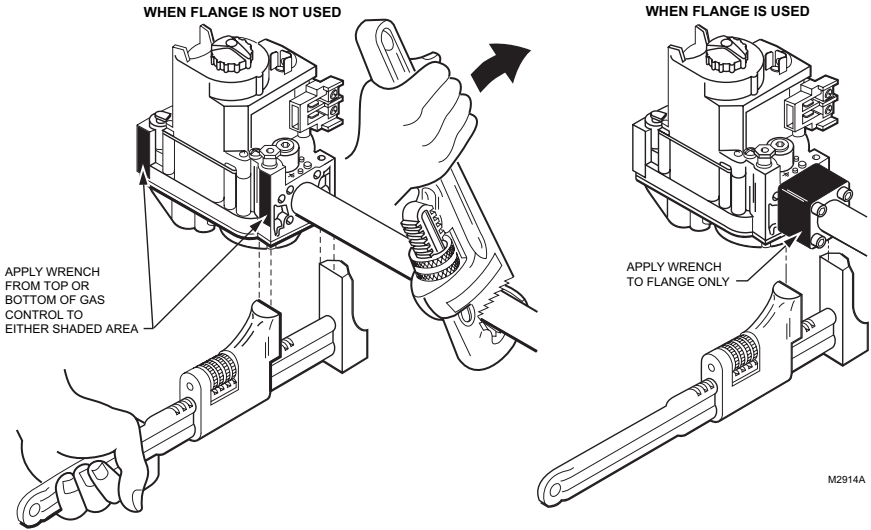

Fig. 6. Proper use of wrench on gas control with and without flanges.

Connect Pilot Gas Tubing

1. Cut tubing to desired length and bend as necessary for routing to pilot burner. Do not make sharp bends or deform the tubing. Do not bend tubing at gas control or pilot burner after compression fitting is tightened, because this may result in gas leakage at the connection.
2. Square off and remove burrs from end of tubing.
3. Unscrew compression fitting from the pilot outlet. (See Fig. 5). Slip the compression fitting over the tubing and slide tubing out of the way.

NOTE: When replacing a gas control, cut off old compression fitting and replace with the new compression fitting provided on the combination gas control. Never use the old compression fitting because it may not provide a gas-tight seal.

4. Push tubing into the pilot gas tapping on the outlet end of the control until it bottoms. While holding tubing all the way in, slide compression fitting into place and engage threads. Turn until finger tight. Then tighten one more turn with a wrench. Do not overtighten. (See Fig. 7).
5. Connect the other end of the tubing to the pilot burner according to the pilot burner manufacturer instructions.

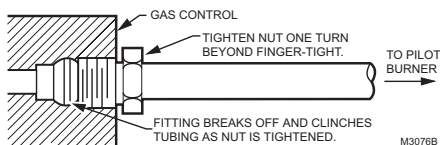

Fig. 7. Always use new compression fitting.

Connect Thermocouple

If a supplementary limit or energy cutoff will be used, insert the ECO connector (order part no. 394332) as shown in Fig. 8. Then connect the thermocouple lead. If not, insert the thermocouple lead directly. This is an electrical connection and must be clean and dry. *Never use pipe compound.* Tighten only 1/4 turn beyond finger tight to give good electrical continuity. *Do not overtighten.*

Wiring

Follow the wiring instructions furnished by the appliance manufacturer, if available, or use the general instructions provided in this section. Where these instructions differ from the appliance manufacturer, follow the appliance manufacturer instructions.

All wiring must comply with applicable electrical codes and ordinances.

Disconnect power supply before making wiring connections to prevent electrical shock or equipment damage.

1. Check the power supply rating on the gas control and make sure it matches the available supply. Install transformer, thermostat and other controls as required.
2. Connect control circuit to gas control terminals. (See Figure 9 or 10).
3. Adjust thermostat heat anticipator to 0.70A rating stamped on valve operator.

Connect Supplementary Limit or ECO (If used)

The leadwires from the high limit or ECO must be equipped with insulated 1/4 in. female quick-connect terminals. Leadwire lengths must not exceed the lengths shown in Tables 5 and 6. Connect the high-limit or ECO leadwires to the two terminals on the ECO connector.

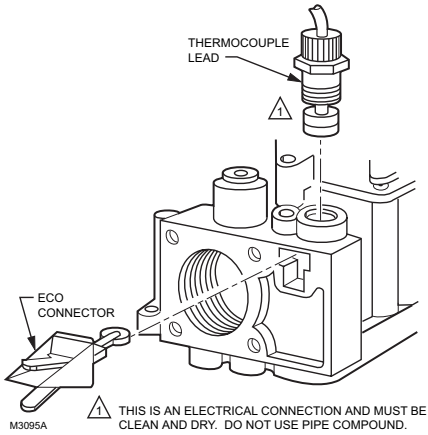

Fig. 8. Installing thermocouple and optional ECO adapter to the power unit.

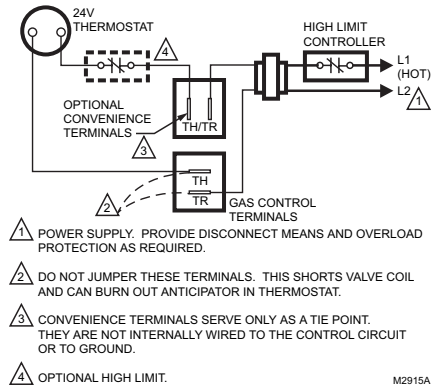

Fig. 9. Wiring connections for V8200 and VR8200 controls.

Table 5. Maximum Length of Supplementary Limit Leadwires When Using Q340A Thermocouple.

Thermocouple Length		Maximum Leadwire Length x 2 (Wires)					
		AWG No. 14		AWG No. 16		AWG No. 18	
Inches	Meters	Inches	Meters	Inches	Meters	Inches	Meters
18	0.5	35	0.9	22	0.6	13	0.3
24	0.6	29	0.7	18	0.5	11	0.3
30	0.8	23	0.6	15	0.4	9	0.2
36	0.9	17	0.4	11	0.3	6	0.2
48	1.2	DO NOT USE					
60	1.5						

Table 6. Maximum Length of Supplementary Limit Leadwires When Using Q309A Thermocouple.

Thermocouple Length		Maximum Leadwire Length x 2 (Wires)					
		AWG No. 14		AWG No. 16		AWG No. 18	
Inches	Meters	Inches	Meters	Inches	Meters	Inches	Meters
12	0.3	47	1.2	30	0.8	18	0.5
18	0.5	41	1.0	26	0.7	16	0.4
24	0.6	35	0.9	22	0.6	14	0.4
30	0.8	29	0.8	18	0.5	11	0.3
36	0.9	23	0.6	15	0.4	9	0.2
40	1.0	19	0.5	12	0.3	7	0.2
48	1.2	11	0.3	7	0.2	DO NOT USE	
60	1.5	DO NOT USE					

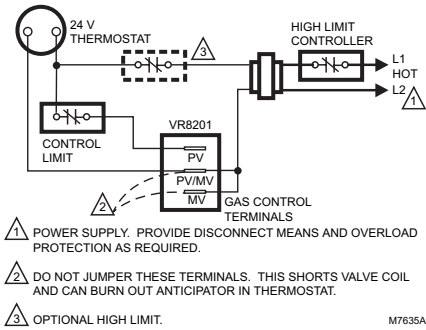

Fig. 10. Wiring connections for VR8201 Control.

1. Paint all pipe connections upstream from the gas control with a rich soap and water solution. Bubbles indicate a gas leak.
2. If a gas leak is detected, tighten the pipe connection.
3. Stand clear while lighting main burner to prevent injury caused from hidden gas leaks that could cause flashback in the appliance vestibule. Light the main burner.
4. With the main burner in operation, paint all pipe joints (including adapters) and gas control inlet and outlet with rich soap and water solution.
5. If another gas leak is detected, tighten adapter screws, joints, and pipe connections.
6. Replace the part if gas leak cannot be stopped.

Light the Pilot Burner Flame

1. Turn the gas control knob clockwise to OFF. Wait five minutes to dissipate any unburned gas. Smell around the appliance near the floor. Do not relight the pilot flame if you smell gas.
2. Turn the gas control knob counterclockwise to PILOT. Push down and hold the gas control knob while lighting the pilot flame.
3. Hold the gas control knob down about one minute, then release.
 - a. If the pilot flame goes out, turn the gas control knob clockwise to OFF and repeat steps 1 through 3.
 - b. If pilot flame remains lit, turn the gas control knob counterclockwise to ON.

Adjust the Pilot Burner Flame

The pilot flame should envelop 3/8 in. to 1/2 in. (10 mm to 13 mm) of the thermocouple tip. (See Fig. 11). To adjust the pilot flame:

1. Remove the pilot adjustment cover screw. (Refer to Fig. 5).
2. Turn the inner adjustment screw clockwise to decrease or counterclockwise to increase the pilot flame.
3. Always replace the cover screw after adjustment and tighten firmly to ensure proper operation.

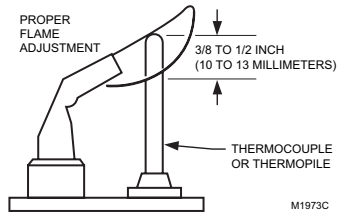

Fig. 11. Proper flame adjustment.

Light Main Burner

Follow the appliance manufacturer instructions or place the thermostat setting above room temperature to call for heat.

STARTUP AND CHECKOUT

WARNING

Fire or Explosion Hazard.
Can cause property damage, severe injury or death.

1. Do not force the gas control knob. Use only your hand to push down the reset button or turn the gas control knob. Never use any tools.
2. If the gas control knob or reset button will not operate by hand, or if the reset button stays depressed after it is released, have a qualified service technician replace the gas control.

Gas Control Knob Settings

The gas control knob has three settings:

- OFF: Prevents pilot and main burner gas flow.
- PILOT: Permits pilot gas flow only. Gas control knob must be held depressed or thermocouple must be heated sufficiently to hold the safety control valve open.
- ON: Permits main burner and pilot gas flow. Gas control and thermostat control main burner gas flow.

NOTE: Gas controls are shipped with the gas knob in the ON position.

Perform Gas Leak Test

WARNING

Fire or Explosion Hazard.
Can cause property damage, severe injury or death.

Check for gas leaks with rich soap and water solution any time work is done on a gas control.

Gas Leak Test

Check and Adjust Gas Input to Main Burner





CAUTION

Equipment Damage Hazard.
Can damage property.

- Do not exceed the input rating stamped on the appliance nameplate, or manufacturer recommended burner orifice pressure for the size orifice(s) used. Ensure the main burner's primary air supply is properly adjusted for complete combustion (refer to the appliance manufacturer instructions).
- If checking gas input by clocking the gas meter:
 - Ensure that the only gas flow through the meter is from the appliance being tested.
 - Ensure that other appliances are turned off and that the pilot burners are extinguished (or deduct the gas consumptions from the meter reading).
 - Convert the flow rate to Btuh as described in the Gas Controls Handbook, form no. 70-2602, and compare to the Btuh input rating on the appliance nameplate.
- If checking gas input with a manometer (pressure gauge):
 - Ensure the gas control knob is in the PILOT position before removing the outlet pressure tap plug to connect the manometer.
 - Turn the gas control knob back to PILOT when removing the manometer and replacing the outlet pressure tap plug.
 - Shut off the gas supply at the appliance service valve or, for LP gas, at the gas tank before removing the outlet pressure tap plug and before disconnecting the manometer and replacing the outlet pressure tap plug.
 - Perform the Gas Leak Test at the inlet pressure tap plug.

Standard Pressure Regulator

- Check the manifold pressure listed on the appliance nameplate. Gas control outlet pressure should match the nameplate.
- With main burner operating, check gas control flow rate using the meter clocking method or pressure using a manometer connected to the outlet pressure tap on the gas control. (See Fig. 4).
- If necessary, adjust the pressure regulator to match the appliance rating. See Table 7 or 8 for factory set nominal outlet pressure and adjustment range.

- Remove pressure regulator adjustment cap screw.
 - Using screw driver, turn inner adjustment screw clockwise  to increase or counterclockwise  to decrease gas pressure to burner.
 - Always replace cap screw and tighten firmly to prevent gas leakage.
- If desired outlet pressure or flow rate cannot be achieved by adjusting the gas control, check gas control inlet pressure using a manometer at the gas control inlet pressure tap. If inlet pressure is in the nominal range (see Table 7 or 8), replace gas control. Otherwise, take the necessary steps to provide proper gas pressure on the control.

Slow-opening and Step-opening Pressure Regulators



- The gas control outlet pressure should match the manifold pressure listed on the appliance nameplate.
- With main burner operating, check gas control flow rate using the meter clocking method or check gas pressure using a manometer connected to the gas control outlet pressure tap. (See Fig. 4).
- If necessary, adjust pressure regulator to match appliance rating. Refer to Table 7 or 8 for factory set nominal outlet pressures and adjustment ranges.
 - Remove pressure regulator adjustment cap and screw.
 - Using screw driver, turn inner adjustment screw clockwise  to increase or counterclockwise  to decrease gas pressure to main burner.
 - Always replace cap screw and tighten firmly to ensure proper operation.
- If desired outlet pressure or gas flow rate cannot be achieved by adjusting the gas control, check gas control inlet pressure using a manometer at the gas control inlet pressure tap. If inlet pressure is in the normal range (refer to Table 7 or 8), replace gas control. Otherwise, take the necessary steps to provide proper gas pressure to the control.
- FOR STEP-OPENING VALVES ONLY. Carefully check main burner lightoff at step pressure. Ensure burner lights smoothly and without flashback to orifice and that all ports remain lit. Cycle burner several times, allowing at least 60 seconds between cycles for regulator to resume step function. Repeat after allowing main burner to cool. Readjust full rate outlet pressure if necessary to improve lightoff characteristics.

Table 7. Pressure Regulator Specification Pressures (in. wc).

Model	Type of Gas	Nominal Inlet pressure Range	Outlet Pressure			
			Nominal Factory Setting		Setting Range	
			Step	Full Rate	Step	Full Rate
Standard, Slow-opening	Natural	5.0 - 7.0	--	3.5	--	3.0 - 5.0
	LP	12.0 - 14.0	--	10.0	--	8.0 - 12.0
Step-opening	Natural	5.0 - 7.0	0.9	3.5	--	3.0 - 5.0
	LP	12.0 - 14.0	2.2	10.0	--	8.0 - 12.0
Unregulated step-opening	Natural	5.0 - 7.0	0.2 ^a	3.5	--	3.0 - 5.0
	LP	12.0 - 14.0	2.0 ^b	10.0	--	8.0 - 12.0

^a Unregulated step pressure at 7.0 in. wc inlet pressure.

^b Unregulated step pressure at 14.0 in. wc inlet pressure.

Table 8. Pressure Regulator Specification Pressures (kPa).

Model	Type of Gas	Nominal Inlet pressure Range	Outlet Pressure			
			Nominal Factory Setting		Setting Range	
			Step	Full Rate	Step	Full Rate
Standard, Slow-opening	Natural	1.2 - 1.7	--	0.9	--	0.7 - 1.2
	LP	2.9 - 3.9	--	2.5	--	2.0 - 3.0
Step-opening	Natural	1.2 - 1.7	0.2	0.9	--	0.7 - 1.2
	LP	2.9 - 3.9	0.9	2.5	--	2.0 - 2.0
Unregulated step-opening	Natural	1.2 - 1.7	0.05	0.8	--	0.7 - 1.2
	LP	2.9 - 3.9	0.5	2.5	--	2.0 - 3.0

^a Unregulated step pressure at 1.7 in. wc inlet pressure.

^b Unregulated step pressure at 3.9 in. wc inlet pressure.

Check Safety Shutdown Performance

WARNING

Fire or Explosion Hazard.
Can cause property damage, severe injury or death.
 Perform the safety shutdown test every time work is done on a gas system.

1. Place gas control knob in PILOT position. Main burner should go off and pilot should remain lit.
2. Extinguish pilot flame. Pilot gas flow should stop within 2-1/2 minutes. Safety shutoff of pilot gas proves complete shutdown because safety shutoff valve prohibits main burner and pilot gas flow.
3. Relight pilot burner and operate system through one complete cycle to ensure all controls operate properly.
4. FOR VR8201: Ensure proper operation of the appliance by confirming that the control limit closes the valve as intended by the appliance manufacturer when the control limit is reached.

MAINTENANCE

WARNING

Fire or Explosion Hazard.
Can cause property damage, severe injury or death.
 Do not attempt to take the gas control apart or to clean it. Improper assembly and cleaning can cause unreliable operation.

Regular preventive maintenance is important in applications that place a heavy load on system controls such as those used in the commercial cooking and agricultural and industrial industries because:

- In many such applications, particularly commercial cooking, the equipment operates 100,000 to 200,000 cycles per year. Such heavy cycling can wear out the gas control in one to two years.
- Exposure to water, dirt, chemicals and heat can damage the gas control and shut down the control system. A NEMA 4 enclosure for the ignition module can reduce exposure to environmental contaminants. See Electronic Ignition Service Handbook, form no. 71-97927.

The maintenance program should include regular checkout of the system as outlined in the Startup and Checkout section, and checkout of the control system as described in the appliance manufacturer literature.

Maintenance frequency must be determined individually for each application. Some considerations are:

- *Cycling frequency.* Appliances that may cycle 20,000 times annually should be checked monthly.

- **Intermittent use.** Appliances that are used seasonally should be checked before shutdown and again before the next use.
- **Consequence of unexpected shutdown.** Where the cost of an unexpected shutdown would be high, the system should be checked more often.
- **Dusty, wet, or corrosive environment.** Because these environments can cause the gas control to deteriorate more rapidly, the system should be checked more often.

Any control should be replaced if it does not perform properly on checkout or troubleshooting. In addition, replace any module if it is wet or looks like it has ever been wet. Protective enclosures, as described in the *Planning the Installation* section, are recommended regardless of checkout frequency.

SERVICE

WARNING

Fire or explosion hazard.

Can cause property damage, severe injury or death.

Do not disassemble the gas control; it contains no replaceable components. Attempted disassembly or repair will damage the gas control.

CAUTION

Equipment Damage Hazard.

Can cause property damage.

Do not apply a jumper across or short the valve coil terminals. This may burn out the heat anticipator in the thermostat.

IMPORTANT

Allow 60 seconds after shutdown before re-energizing the step-opening model to ensure lightoff at step pressure.

If the Pilot Burner Flame Will Not Light

1. Ensure the main gas supply valve is open and the pilot gas supply line is purged of air.
2. Attempt to light pilot burner flame following procedures in *Light the Pilot Burner Flame* section. If pilot burner flame still will not light:
 - a. Check the pilot gas adjustment screw. If closed, readjust the pilot flame. Refer to *Adjust the Pilot Burner Flame* section.
 - b. Perform the Gas Leak Test at the compression fitting. If a gas leak is detected, replace the old compression fitting or tighten the newly installed one. (Refer to Fig. 7).
 - c. Ensure that the pilot burner tubing or pilot burner orifice is not clogged.

If the Pilot Burner Flame Goes Out When the Gas Control Knob is Released

1. Ensure the gas control knob is held in at least one minute to allow the thermocouple time to heat.
2. Check the pilot burner flame adjustment. Refer to *Adjust the Pilot Burner Flame* section.
3. Check the wiring between the thermocouple and the gas control valve operator.
4. Ensure thermocouple connection to the power unit is tightened 1/4 turn beyond finger tight.
5. If pilot burner flame still goes out, measure the open and closed thermocouple output voltage. Compare it to the acceptable range charts in the thermocouple specifications or in the *Gas Controls Handbook*. Replace the thermocouple if voltages are outside the acceptable range.
6. Check the power unit resistance. If above 11 ohms, replace the gas control.

If the Main Burner Will Not Come on with a Call for Heat

1. Ensure the gas control knob is in the ON position.
2. Adjust the thermostat several degrees above room temperature.
3. Use an ac voltmeter to measure the voltage across terminals TH and TR on the V8200 and VR8200. On the VR8201, measure the voltage across PV and PV/MP first and then across MP and PV/MP.
 - a. If no voltage is present, check the control circuit for proper operation.
 - b. If proper control system voltage is present, but first operator did not click open, check for excessive inlet gas pressure. If inlet gas pressure is correct, replace the gas control.
4. Measure the open and closed thermocouple output voltages and compare to the acceptable range charts in the *Thermocouple Specifications* or in the *Gas Controls Handbook*. Replace the thermocouple if voltages are outside the acceptable range.

If the Main Burner is Overfiring

Adjust the gas control pressure regulator to the correct pressure. If the regulator cannot be adjusted and supply pressure is in the normal range, replace the gas control.

INSTRUCTIONS TO THE APPLIANCE OWNER

For Your Safety, Read Before Lighting

WARNING

Fire or Explosion Hazard.

Can cause property damage, severe injury or death.

IF YOU DO NOT EXACTLY FOLLOW THE WARNINGS BELOW AND THE LIGHTING INSTRUCTIONS, A FIRE OR EXPLOSION CAN RESULT IN PROPERTY DAMAGE, PERSONAL INJURY OR LOSS OF LIFE.

1. Before lighting, smell all around the appliance area for gas. If the appliance uses LP (bottled) gas, also be sure to smell next to the floor because LP gas is heavier than air. If you smell gas, immediately shut off the manual valve in the gas piping to the appliance, or ON LP, AT THE TANK. Do not try to light any appliance. Do not touch any electrical switch or use the phone. LEAVE THE BUILDING and call your gas supplier. If your gas supplier cannot be reached, call the fire department.
2. Do not force the gas control knob on the appliance. Use only your hand to push down the reset button or turn the gas control knob. Never use any tools. If the knob or reset button will not operate by hand, replace the control using a qualified service technician. Force or attempted repair can result in fire or explosion.
3. Replace the gas control if it has been flooded with water. Call a qualified service technician.
4. If the red reset button stays depressed after it is released, replace the gas control.
5. The gas control is a safety device. It must be replaced in event of any physical damage such as bent terminals, missing or broken parts, stripped threads, or evidence of exposure to heat.



IMPORTANT

Follow the operating instructions provided by the manufacturer of your heating appliance. Use the information below for a typical control application; however, the specific controls used and the procedures outlined by the manufacturer of your appliance can differ, requiring special instructions.

To Light the Pilot Burner

STOP: Read the safety information.

This appliance has a pilot burner that must be lit by hand. If the pilot flame has gone out, follow these instructions exactly:

1. Set thermostat to lowest setting and shut off electric power to appliance.
2. Remove burner access panel if provided on your appliance.
3. Turn gas control knob (see Fig. 4) clockwise  to OFF position.
4. Wait five minutes to allow any gas in the combustion chamber to vent. If you then smell gas in the appliance area or near the floor in an LP installation, immediately shut off the manual valve in the gas piping to the appliance or, WITH LP, SHUT OFF AT THE TANK. Do not touch any electrical switch or use the phone. LEAVE THE BUILDING and call your gas supplier. If your gas supplier cannot be reached, call the fire department. Failure to do so may result in fire or explosion.
5. If you do not smell gas, turn the knob on the gas control counterclockwise  to pilot.
6. Push and hold down the red reset button (see Fig. 4) while you light the pilot burner. Continue to hold the reset button down for about one minute after the pilot is lit. Release button; pilot should remain lit. If it goes out, repeat steps 3 through 6. If the reset button does not pop up when released, stop immediately and call your service technician or gas supplier. If pilot does not remain lit after several tries, turn gas control knob to OFF and call your service technician or gas supplier.
7. When pilot remains lit, turn gas control knob counterclockwise  to ON.
8. Replace burner access panel.
9. Turn on power.
10. Set thermostat to desired temperature.

To Turn Off Appliance

VACATION SHUTDOWN

Turn gas control knob clockwise  from ON to PILOT. Pilot remains lit, ready for return to normal service without relighting.

COMPLETE SHUTDOWN

Turn gas control knob clockwise  to OFF. Both pilot and main burner are shut off. The pilot must be manually relit when normal burner operation is desired.

Automation and Control Solutions

Honeywell International Inc.
1985 Douglas Drive North
Golden Valley, MN 55422
customer.honeywell.com

Honeywell Limited-Honeywell Limitée
35 Dynamic Drive
Toronto, Ontario M1V 4Z9