

Compact I/O Module

XIO-4AO LON[®] ANALOG OUTPUT MODULE

INSTALLATION INSTRUCTIONS



GENERAL

The Honeywell XIO-4AO LON[®] Analog Output Module is a LON module with 4 analog outputs. The outputs supply a voltage between 0 and 10 V, and the voltage can be adjusted by LNS[®]-Plugin.

In a LON installation, the different outputs are activated proportionally by the network variables, SNVT. According to the SNVT settings, they provide a voltage between 0 and 10 Volts. In addition, depending on a binary state, the outputs can be set to a previously defined value. The manual position of the potentiometer is signalled.

SPECIFICATIONS

Electrical Ratings:

Supply Operating Voltage: 20 to 28 V AC/DC.
Current Consumption: 150 mA (AC) / 70 mA (DC).
Duty cycle: 100%.
Recovery time: 550 ms.

Terminal Blocks:

Supply and Bus: 16 AWG (1.5 mm²).
(terminal block and strapping plug included with packing).
Analog Outputs: 14 AWG (2.5 mm²).

LON Interface:

Transceiver: FTT10A free topology.
Neuron: FT3150, 64K Flash downloadable.
Data format: standard network variables (SNVT).
Transmission rate: 78 kBit/s.
Maximum Length:
Line topology: 8858 ft. (2700 m) / 64 nodes.
Free topology: 1640 ft. (500 m) / 64 nodes.
Cabling: Twisted Pair.

Display:

Operation: green LED.
Function: yellow LED for status (service).

Temperature Ratings:

Operating: 23° F to 131° F (-5 °C to +55 °C).
Storage: -4° F to +158° F (-20 °C to +70 °C).

Dimensions (W x H x D):

1.4 x 2.8 x 2.6 in. (35 x 70 x 65 mm).

Weight: 3 ounces (84 grams).

Mounting Position: Any.

Mounting: DIN rail per EN 50022.

Output:

Output voltage: 0 to 10 V DC.
Output current (10 VDC): 5 mA.
Resolution: 10 mV.
Error: maximum ±100 mV.

Construction Material:

Housing and Terminal Blocks: Polyamide 6.6 V0.
Faceplate: Polycarbonate.

Protective circuitry:

Operating voltage: polarity reversal protection.

Protection:

IP40 housing DIN 40050.
IP20 terminal blocks DIN 40050.



SAFETY INSTRUCTIONS

NOTES REGARDING DEVICE DESCRIPTION

These instructions include indications for use and mounting of the device. In case of questions that cannot be answered with these instructions, please consult the product supplier or manufacturer. It is the responsibility of the equipment installer to ensure that all federal, state and local codes are followed.

SAFETY INSTRUCTIONS

- Keep these Installation Instructions for industrial safety and the prevention of accidents.
- Only qualified personnel shall do mounting and installation work with these devices, see section titled “Qualified Personnel”.
- The information in these instructions must be read and understood by every person using this device.

QUALIFIED PERSONNEL

Qualified personnel in the sense of these instructions are persons who are well versed in the use and installation of such devices and whose professional qualification meets the requirements of their work.

This includes, for example:

- Qualification to connect the device according to applicable specifications and regulations, and a qualification to put this device into operation, to power it down, or to activate it by respecting the internal directions.
- Knowledge of safety rules.
- Knowledge about application and use of the device within the equipment system.

BEFORE INSTALLATION

1. Unpack the XIO-4AO Universal LON Analog Output Module.
2. Check the equipment and report any damage to a Honeywell representative.
3. Read all of these instructions and ensure they are understood.

MOUNTING

Mount the XIO-4AO Universal LON Analog Output Module on standard DIN rail per DIN EN 50022 (1.35 x 0.3 in. [35 x 7.5 mm]), in junction boxes and/or on distribution panels.

INSTALLATION



CAUTION

Electrical installation and device termination shall be accomplished by qualified persons only, by respecting all applicable specifications and regulations.

1. Power down the equipment. Mount the module on the DIN rail.

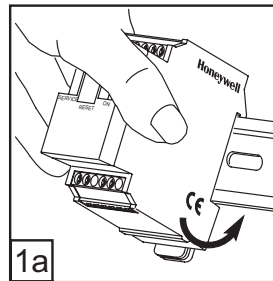

M25060

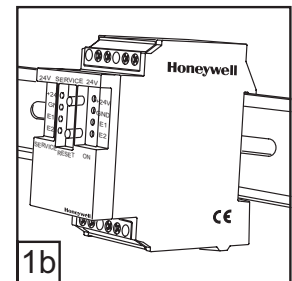

M25061

2. Plug in the terminal block for bus connection.

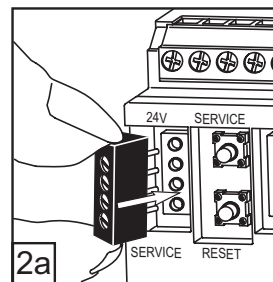

M25062

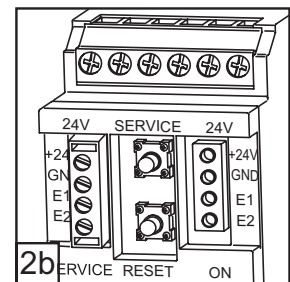

M25063

3. Prepare the cable for bus connection:

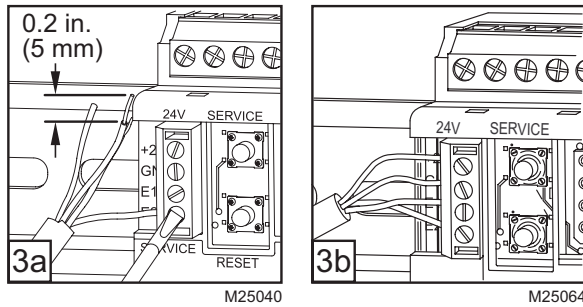

- Remove about 0.75 in. (2 cm) of the plastic cable sheath.
- Strip 0.2 in. (5 mm) insulation from each wire. Put a wire end sleeve on stranded wires.
- Insert the wire to the respective contact and secure it by screwing down the contact screw.
- Wire cross section of the 4 pole terminal block bus/main connection:
 - Maximum 16 AWG (1.5 mm²) single wire.
 - Maximum 18 AWG (1.0 mm²) stranded wire.
 - Wire diameter minimum 28 AWG (0.3 mm) up to 16 AWG (1.4 mm).

4. Prepare cable for module connections.

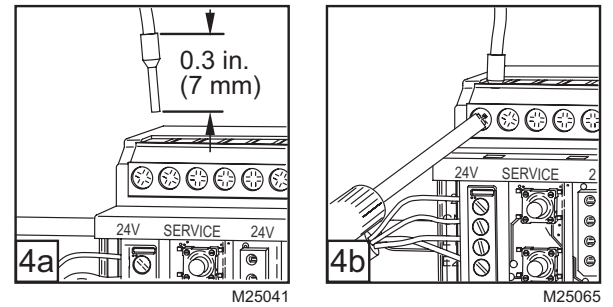

- Strip the wires by 0.3 in. (7 mm). Put a wire end sleeve on stranded wires.
 - Insert the wire into the respective module contact and secure it by screwing down the contact screw.
 - Wire cross section of the module contacts:
 - Maximum 12 AWG (4.0 mm²) single wire.
 - Maximum 14 AWG (2.5 mm²) stranded wire.
 - Wire diameter: minimum 28 AWG (0.3 mm) up to maximum 10 AWG (2.7 mm).
5. The module can be aligned without interspace. Use the strapping plug to connect bus and supply voltage when the modules are mounted in series. The modules can be mounted in series without interspace. The maximum number of modules connected in series is 15, with each group needing an external power supply.

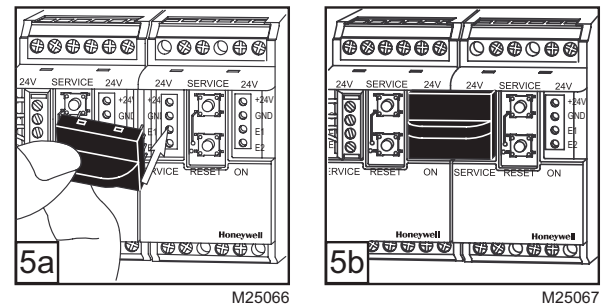

TERMINATION

Fig. 1 shows the termination points of the XIO-4AO.

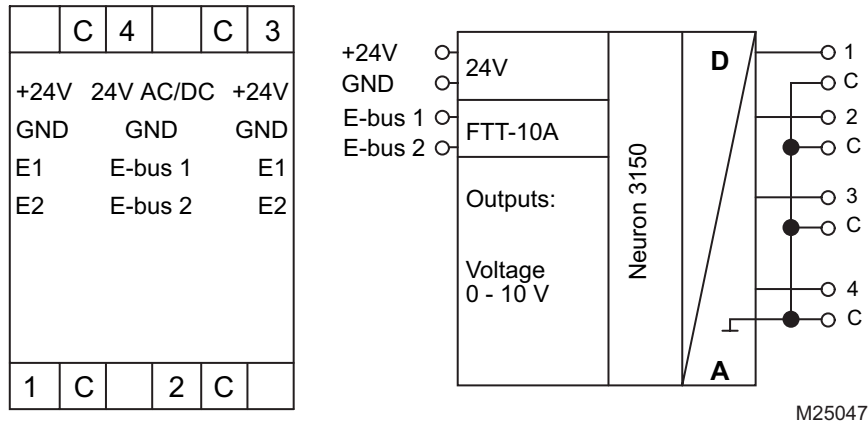
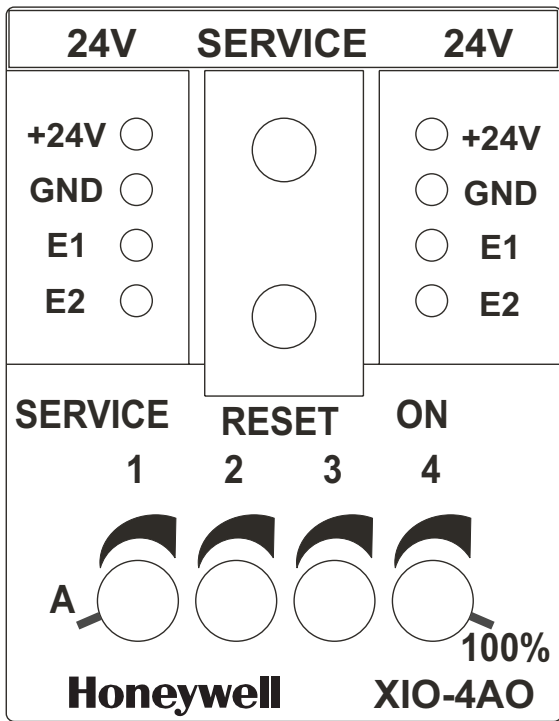

Fig. 1. Termination diagram for the XIO-4AO.

WIRING

Wiring of the XIO-4AO must be accomplished in accordance with federal, state, and local requirements. Figures 2 and 3 show sample diagrams of wiring of the XIO-4AO.



M25074

Fig. 2. Front panel diagram of XIO-4AO.

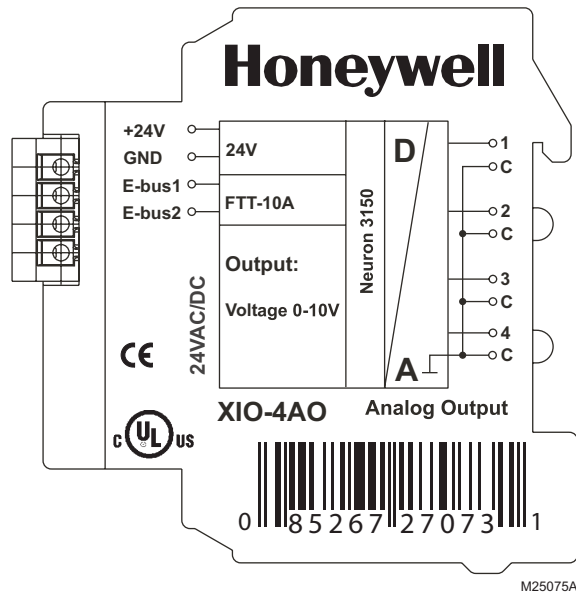

M25075A

Fig. 3. Side panel diagram of XIO-4AO.

SOFTWARE DESCRIPTION

The Node Object monitors and controls the functions of the different objects in the device. It supports the basic functions Object-Status and Object-Request required by LonMark®. Refer to Fig. 4 for a basic illustration of Node Objects. The following objects are monitored by the Node Object:

nviRequest	NVT_obj_request
nvoStatus	SNVT_obj_status
nvoFileDirectory	SNVT_address

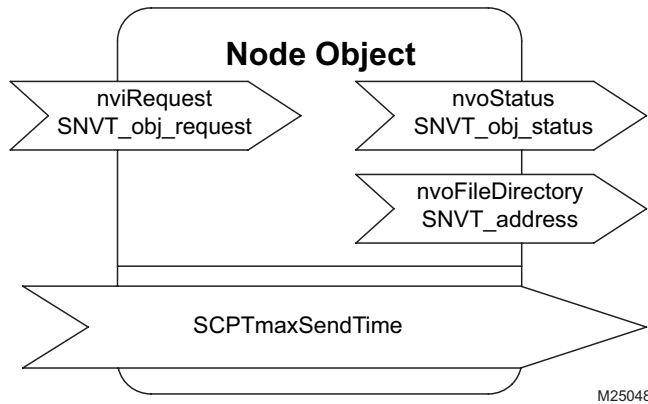

Fig. 4. XIO-4AO Node Object.

SCPTmaxSendTime	SNVT_time_sec
------------------------	----------------------

All output variables described below will be issued at the latest at the end of the preset period even without status change. Time settings:

0 timer function off-state
6553.4 s (factory setting 60 s)

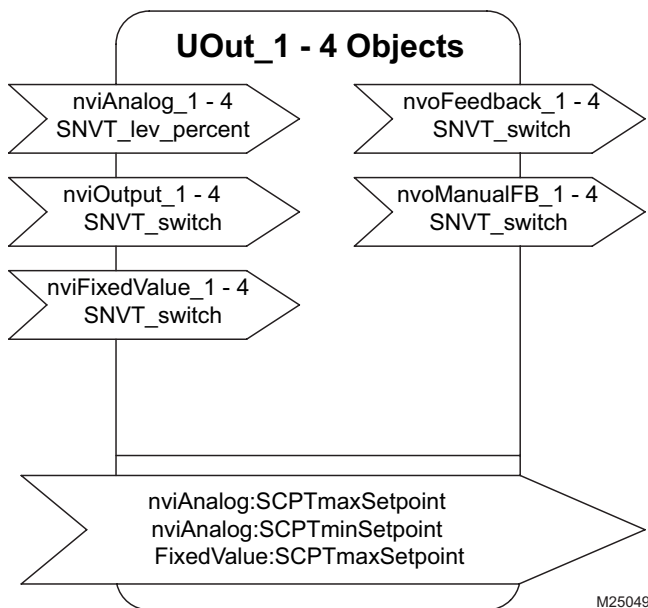

Fig. 5. XIO-4AO UOut Objects.

nviAnalog_1...4	SNVT_lev_percent
------------------------	-------------------------

The output signal voltages corresponding to the variables.
 $nviAnalog_{1...4} = 0...100\%$
 $Output_{1...4} = 0...10\text{ V DC}$

nviOutput_1...4	SNVT_switch
------------------------	--------------------

The outputs signal voltages corresponding to the value portion of the variables. The state portion is discounted.
 $nviOutput_{1...4} = 0...100\% \times$
 $Output_{1...4} = 0...10\text{ V DC}$

The input variables described above are equal. The output supplies the last received value. Therefore it is necessary to work without Heartbeat when using both input variables.

nviFixedValue_1...4	SNVT_switch
----------------------------	--------------------

Overrides the outputs to the percentages that are preset in SCPTmaxSetPoint. Only the state portion will be interpreted.
 $nviFixedValue_{1...4} = x.x (-)1$
 $Output_{1...4} = SCPTmaxSetpoint$
 $nviFixedValue_{1...4} = x.x 0$
 $Output_{1...4} = nviAnalog_{1...4}$ or
 $nviOutput_{1...4}$

nvoFeedback_1...4	SNVT_switch
--------------------------	--------------------

Transmits the feedback value of the object. The value portion transmits the value of $nviAnalog_{1...4}$ or value portion of $nviOutput$. The state portion transmits the operation mode:
 Automatic: $x\% +1$
 Manual: $x\% -1$

nvoManualFB_1...4	SNVT_switch
--------------------------	--------------------

Transmits feedback of manual operation.
 Potentiometer on left stop = Automatic 100,0 1
 Potentiometer not on left stop = manual 0,0 0

nviAnalog:SCPTmaxSetpoint	SNVT_lev_percent
----------------------------------	-------------------------

Upper range limit of the output in percent. When entering 85% for example the output adopts a voltage of 8.5 V with a value of 100% in the input variables.
 Value settings: 0...100%

nviAnalog:SCPTminSetpoint	SNVT_lev_percent
----------------------------------	-------------------------

Lower range limit of the output in percent. When entering 15% for example the output adopts a voltage of 1.5 V with a value of 0% in the input variables. The total range results of both settings. When $maxSetpoint = 85$ and $minSetpoint = 15$ and an input value between 0 and 100% of a voltage between 1.5 and 8.5 results at the output.
 Value settings: 0...100%

FixedValue:SCPTmaxSetpoint	SNVT_lev_percent
-----------------------------------	-------------------------

Preset percentage when using $FixedValue_{1...4}$.
 Value settings: 0...100%

By using this Honeywell literature, you agree that Honeywell will have no liability for any damages arising out of your use or modification to, the literature. You will defend and indemnify Honeywell, its affiliates and subsidiaries, from and against any liability, cost, or damages, including attorneys' fees, arising out of, or resulting from, any modification to the literature by you.

Automation and Control Solutions

Honeywell International Inc.
1985 Douglas Drive North
Golden Valley, MN 55422
customer.honeywell.com

Honeywell Limited-Honeywell Limitée
35 Dynamic Drive
Scarborough, Ontario M1V 4Z9

